

2018

# HYDRAULIC RESCUE SYSTEMS



TEAM  
*gold*  
licence to cut

[www.weber-rescue.com](http://www.weber-rescue.com)

**WEBERRESCUE**  
SYSTEMS

## WITH NEW TECHNOLOGIES INTO THE FUTURE

New vehicle technologies and continuously optimised safety systems in vehicles improve the protection of the occupants. However, they are always presenting new challenges for the emergency services. WEBER RESCUE SYSTEMS provides for this trend by continuously developing high-performance rescue systems.

We have the right rescue equipment for practically any scenario. In recent years, our innovations have been focused around flexible, battery-operated tools in the E-FORCE series. However, our standard range has also been advanced with new generations of cutters and blades (RSU PLUS), new spreaders (AS and BS spreaders) and power units (E/V 70 W).

We offer a comprehensive range of tried-and-tested solutions, now complemented by additional equipment such as the STAB-FAST ALU, PAT-STAB and PAT-SAFE.

A further component of our success is our worldwide training and education programmes for emergency service personnel. An example of this is our RESCUE DAYS events, which are now held in multiple countries (Austria, Brazil, Japan, etc.) and at which thousands of fire service and rescue personnel have already been trained.

You can get the best overview of the many advantages of our systems during a personal product presentation at your own location, where you can discover for yourself what lies behind the experience of WEBER RESCUE products.

You can find more interesting information on our products and services at [www.weber-rescue.com](http://www.weber-rescue.com).

The WEBER RESCUE Sales Team

**WEBER**RESCUE  
SYSTEMS

## CONTENT

NEW TECHNOLOGIES	4
SPREADERS	6
CUTTERS	10
COMBI TOOLS	16
RESCUE RAMS	20
POWER UNITS	24
COMPACT POWER UNITS AND HOSES	28
E-FORCE 2 BATTERY TOOLS	34
LIGHT-TOOLS	44
LIFTING EQUIPMENT	46
STABILISATION	50
ACCESSORIES	56
FANSHOP	66
TRAINING	66

**WEBER**  
*Instructor*

## WEBER RESCUE PRODUCTS WITH THE LATEST TECHNOLOGIES!

 <b>PLUS</b>	Changeable inserts made of high strength alloy
 <b>COAX</b>	Hose-in-hose-system for better handling
 <b>SINGLE</b>	Quick and easy connection of hoses with one movement without unintended release
 <b>360° HANDLE</b>	Rotatable (360°) and detachable handle
 <b>CHARGE</b>	Rechargeable Li-Ion batteries for independent operation
 <b>XTREME</b>	Xtreme cutting technology for excellent cutting, especially for latest materials
 <b>COMPACT</b>	Best capacity on minimum space and low weight
 <b>ECO</b>	Removes extra noise and stress by automatic speed control
 <b>TURBO-SPEED</b>	Maximum power through double speed „turbo“ operation of one tool
 <b>PUSH-CONTROL</b>	Unique WEBER control for fine tuned precision handling
 <b>GRIP</b>	Spikes for extra grip
 <b>ULTIMATE</b>	High-strength, forged blades for hardest applications
 <b>PERFORMANCE</b>	Higher working speed by means of more power
 <b>EXTENDABLE</b>	Creates space in the interior
 <b>DISTANCE</b>	Rescue rams with integrated remaining length marking

## NEW GENERATION OF CUTTERS

**RSU**

 **ULTIMATE**



Blades	ULTIMATIVE	others
Cutting performance	+++	+
Stability/ Safety	+++	+
Blade inserts	✓	✗
Weight	3.6 kg	3.9 kg

High-strength, forged lightweight design blades  
 Further optimised **ULTIMATE** blade design for hardest applications  
 Adjustable fibre-reinforced handle for perfect handling

## THE NEW MOBILITY **E FORCE 2**

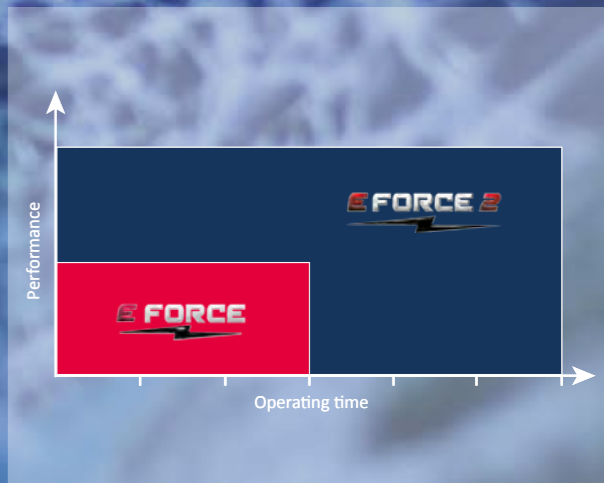

New, efficient and improved drive unit for longer working time at higher speed  
 LED lights for better view in the working area  
 Long operating time due to 5.0 Ah capacity

# USE MEETS BITE

WEBER RESCUE high performance spreaders

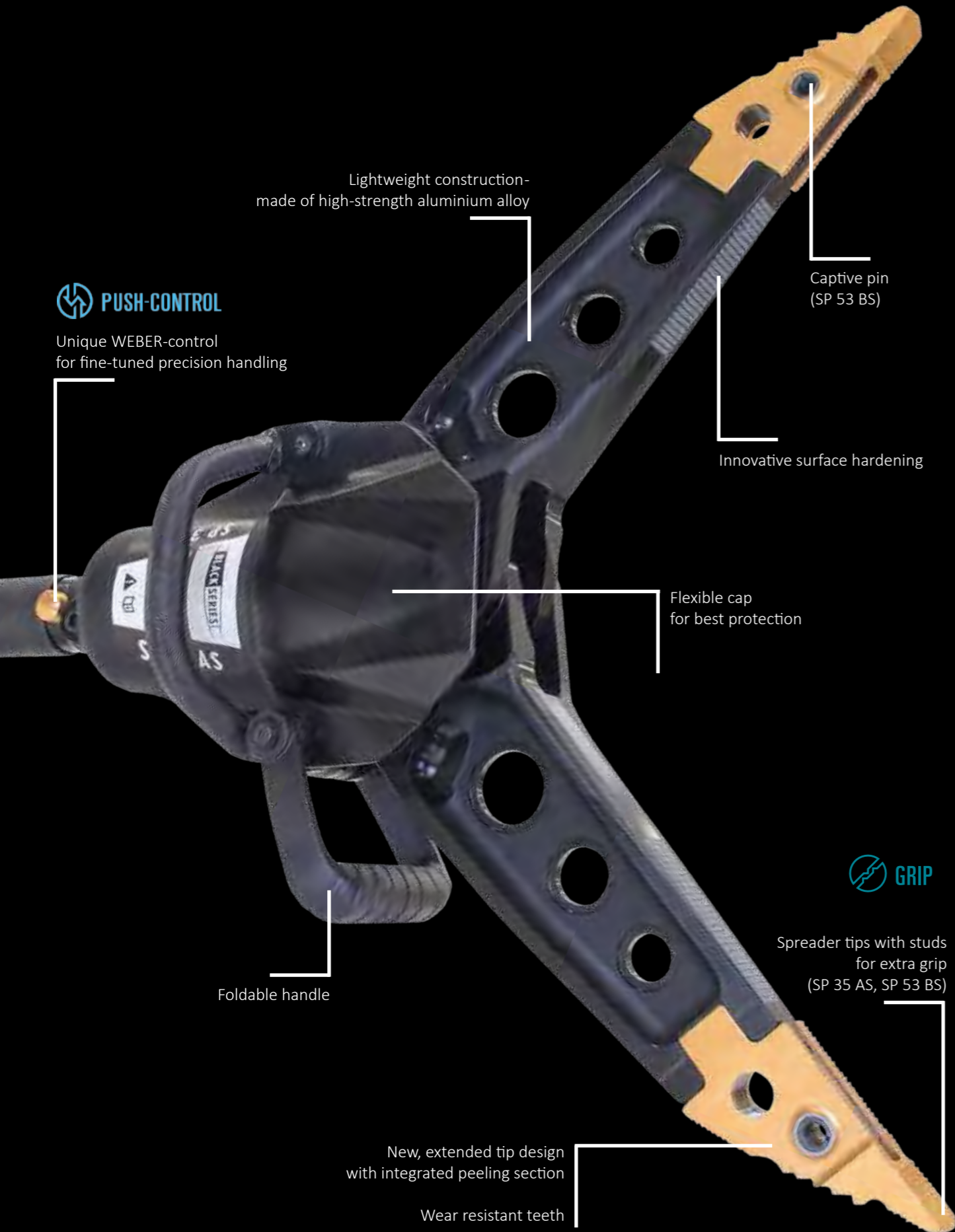

# TIPS AND TRICKS FISH CAN

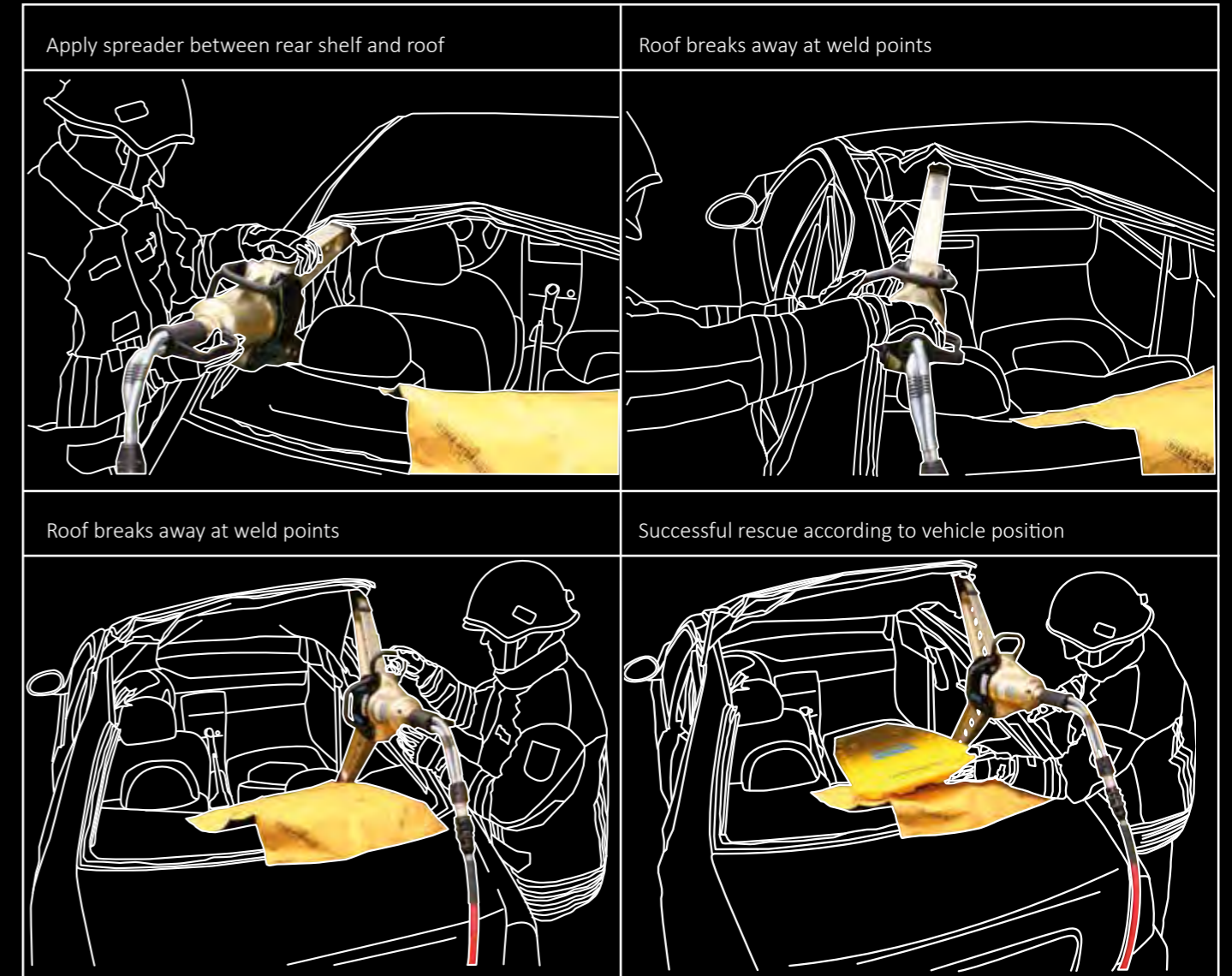

# SPREADERS

Type	SP 35 AS	SP 49	SP 53 BS	SP 60	SP 80
Spreading force in working range*	35-171 kN	49-422 kN	53-421 kN	63-492 kN	87-470 kN
Closing force*	76 kN	115 kN	100 kN	110 kN	102 kN
Spreading distance	600 mm	710 mm	800 mm	810 mm	620 mm
Weight	14.6 kg	20.1 kg	20.3 kg	24.7 kg	25.1 kg
EN class	AS 35/600-15	AS 49/710-20,1	BS 53/800-20	BS 63/810-24.7	CS 87/600-25
Part no.	1071373	5933633	1058125	5931479	5930758

\*according to EN 13204 to 700 bar



## SP 35 AS

- Lightweight spreader (only 14.6 kg)
- Long arms for extra control and stability
- Large opening of 600 mm
- New tips with studs for extra grip
- Meets AS classification



## SP 53 BS

- One of the most lightweight BS spreader (EN class) worldwide
- Ideally suited to today's automotive materials and demands!
- Large opening of 800 mm
- Captive pin and new tips with studs for extra grip
- Meets BS classification



SP 35 AS



SP 53 BS

TEAM  
*gold*  
Power redefined

# SPREADERS



SP 49



SP 60



SP 80

Replacement tips	
SP 35 AS	1074746
SP 49	3885593
SP 53 BS	1068392
SP 60	3878368
SP 80	3878376

## ACCESSORIES

**Chain set** consisting of:  
2 pcs. chain lock, 2 pcs. pulling chain 1.8 m long with hooks. The length of chains can easily be adjusted through a push-button at the chain lock.

SP 53 BS	571415
SP 35 AS, SP 49 und SP 60	2819139
SP 80	2840138



# THE NEW GENERATION OF CUTTERS

THE ULTIMATIVE Cutter with blade inserts



# TIPS AND TRICKS

## TWIST GRIP



Further optimised blade- and cutting edge design for hardest applications

Unique WEBER-control for fine-tuned precision handling



Rotatable and detachable handle- ideal for restricted and confined space operation



High-strength, forged lightweight design blades

Replaceable blade inserts for long lasting performance

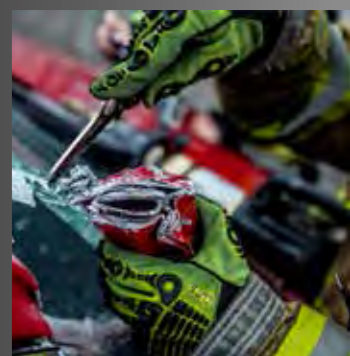
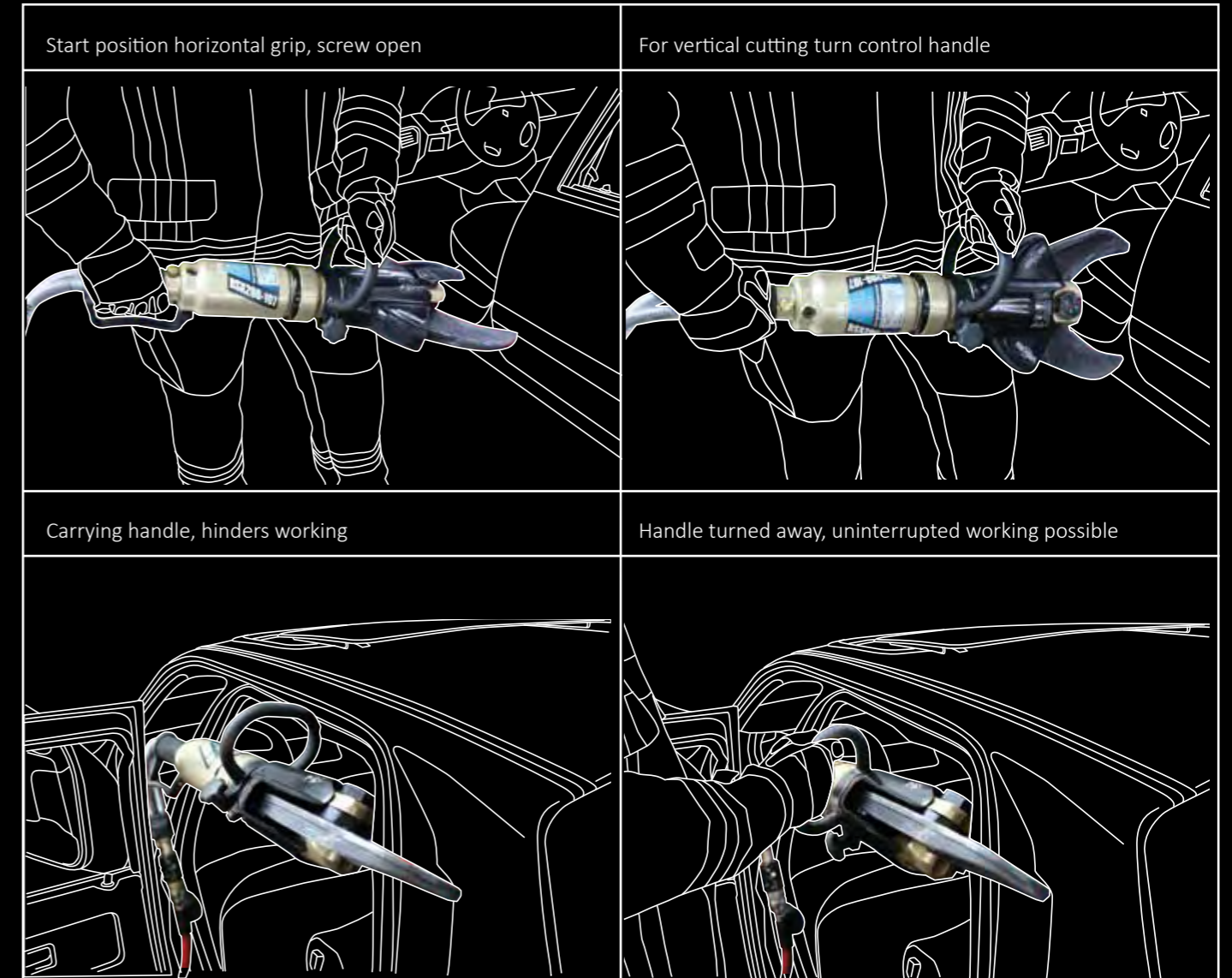

# CUTTERS

## THE PROVEN BLADE SHAPE - RSX

Type	RSX 105-29	RSX 160-50	RSX 180-80
Opening	105 mm	163 mm	180 mm
Max. cutting force*	29 t/282 kN	70 t/683 kN	92 t/903 kN
Weight	9.3 kg	14.6 kg	17.6 kg
EN class	AC 100-D-9,3	BC 160-H-14,6	BC 180-I-17,6
Cutting performance (EN 13204)	1E-2E-3E-4D-5G	1I-2K-3H-4J-5H	1J-2K-3I-4J-5J
NFPA class	A5/B4/C5/D6/E6	A7/B8/C6/D7/E8	A7/B9/C7/D9/E9
Part no.	5936780	1050539	1059226

Type	RSX 185-105	RSX 200-107
Opening	185 mm	200 mm
Max. cutting force*	105 t/1.030 kN	107 t/1.050 kN
Weight	22.5 kg	19.7 kg
EN class	CC 240-K-22,5	CC 200-J-19,7
Cutting performance (EN 13204)	1K-2K-3K-4K-5K	1J-2K-3K-4K-5K
NFPA class	A9/B9/C9/D9/E9	A8/B9/C8/D9/E9
Part no.	5932939	5935849

\*according to EN 13204 to 700 bar

## ACCESSORIES

Replacement blade	Part no.	Weight
RSX 105-29	1825518	1.1 kg
RSX 160-50	1050557	2.3 kg
RSX 180-80	1059813	3.2 kg
RSX 185-105	1823035	4.0 kg
RSX 200-107	1822608	3.4 kg

Upgrade to RSX 180-80 PLUS:		
	Weight	Part no.
RS 170	8.3 kg	1062138
RS(X) 165-65, S 270-71	8.3 kg	1062134



# NEW GENERATION OF CUTTERS

# RSU



Type	RSU 180 PLUS	RSU 210 PLUS
Opening	180 mm	210 mm
Weight	16.9 kg	19.6 kg
EN class	BC 180-J-16,9	CC 200-K-19,6
Cutting performance (EN 13204)	1J-2K-3K-4K-5K	1K-2K-3K-4K-5K
NFPA class	A8/B9/C7/D9/E9	A8/B9/C8/D9/E9
Part no.	1080423	1087572

## ACCESSORIES

Upgrade to RSU 210 PLUS:		
	Content	Part no.
RS 200-107, RSX 200-107, RSX 200-107 PLUS	Blade complete, pin	1089015

Replacement blade	Weight	Part no.
<b>Blade without insert</b>		
RSU 180 PLUS	2.7 kg	1084723
RSU 210 PLUS	3.0 kg	1087420
<b>Blade insert</b>		
RSU 180 PLUS and RSU 210 PLUS	0.3 kg	1084724
<b>Blade complete (with insert)</b>		
RSU 180 PLUS	3.0 kg	1081085
RSU 210 PLUS	3.3 kg	1087581
<b>Inserts in bag (2 pcs.)</b>		
RSU 180 PLUS and RSU 210 PLUS	1.1 kg	1084725

Only one insert for two cutters!



# SPECIALISED CUTTERS

## C 100-31

- Specialised tool for continuous cutting
- Surplus materials is automatically removed
- Special serrated surface for aggressive cutting

Opening	120 mm
Max. cutting force*	31 t/308 kN
Weight	19.5 kg
EN class	AC 120-D-19,5
Cutting performance (EN 13204)	1D-2D-3E-4F-5F
NFPA class	A4/B3/C5/D6/E6
Part no.	5935199

Replacement blade:	
C 100-31 Blade	1051463
C 100-31 Lower blade right	1051474
C 100-31 Lower blade left	1051475



## S 220-54 AND S 270-71

- Very large opening width
- Serrated blades
- Low weight

	S 220-54	S 270-71
Opening	220 mm	280 mm
Max. cutting force*	54 t/533 kN	71 t/699 kN
Weight	14.4 kg	16.6 kg
EN class	BC 170-H-14,4	CC 218-I-16,6
Cutting performance (EN 13204)	1I-2H-3H-4K-5I	1I-2K-3I-4K-5J
NFPA class	A7/B7/C6/D8/E8	A7/B8/C7/D8/E9
Part no.	1063372	5932084

Replacement blade:	
S 220-54 Blade	1063374
S 270-71 Blade	1808559



## S 50-14

- Tension-free cutting, no uncontrolled movement of the material being cut
- Compact – for use in confined spaces such as vehicle foot wells
- Lightweight – for one-handed operation

Opening	50 mm
Max. cutting force*	19 t/181 kN
Weight	4.3 kg
EN class	AC 50-B-4,3
Cutting performance (EN 13204)	1C-2D-3B
NFPA class	A4/B3/C2/D4/E3
Part no.	2833395

Replacement blade:	
S 50-14 Upper blade	3863670
S 50-14 Lower blade	3863689



## CONCRETE CRUSHER BC 250

- For heavy operation in event of natural disasters, collapsed buildings and industrial incidents
- To break away thick pieces of concrete
- Rotatable grip handle and protection shield
- Changeable tips
- Also available in battery version (E-FORCE)

Opening	250 mm
Max. closing force*	11 t/109 kN
Weight	18.1 kg
Part no.	1063190

BC 250 Replacement tips	1065132
-------------------------	---------



## CUTTER S 25-20

- Rescue tool for disasters, such as earthquakes and building collapses
- For cutting of metal rods, chains, locks and reinforcements
- One-handed operation possible

Max. cutting force*	19,5 t/191 kN
Weight	7.7 kg
Part no.	1065612

S 25-20 Replacement tips	1065665
--------------------------	---------



\*according to EN 13204 to 700 bar



# EFFICIENCY MEETS VARIETY

*Cutting, spreading, pushing and pulling - with one tool!*

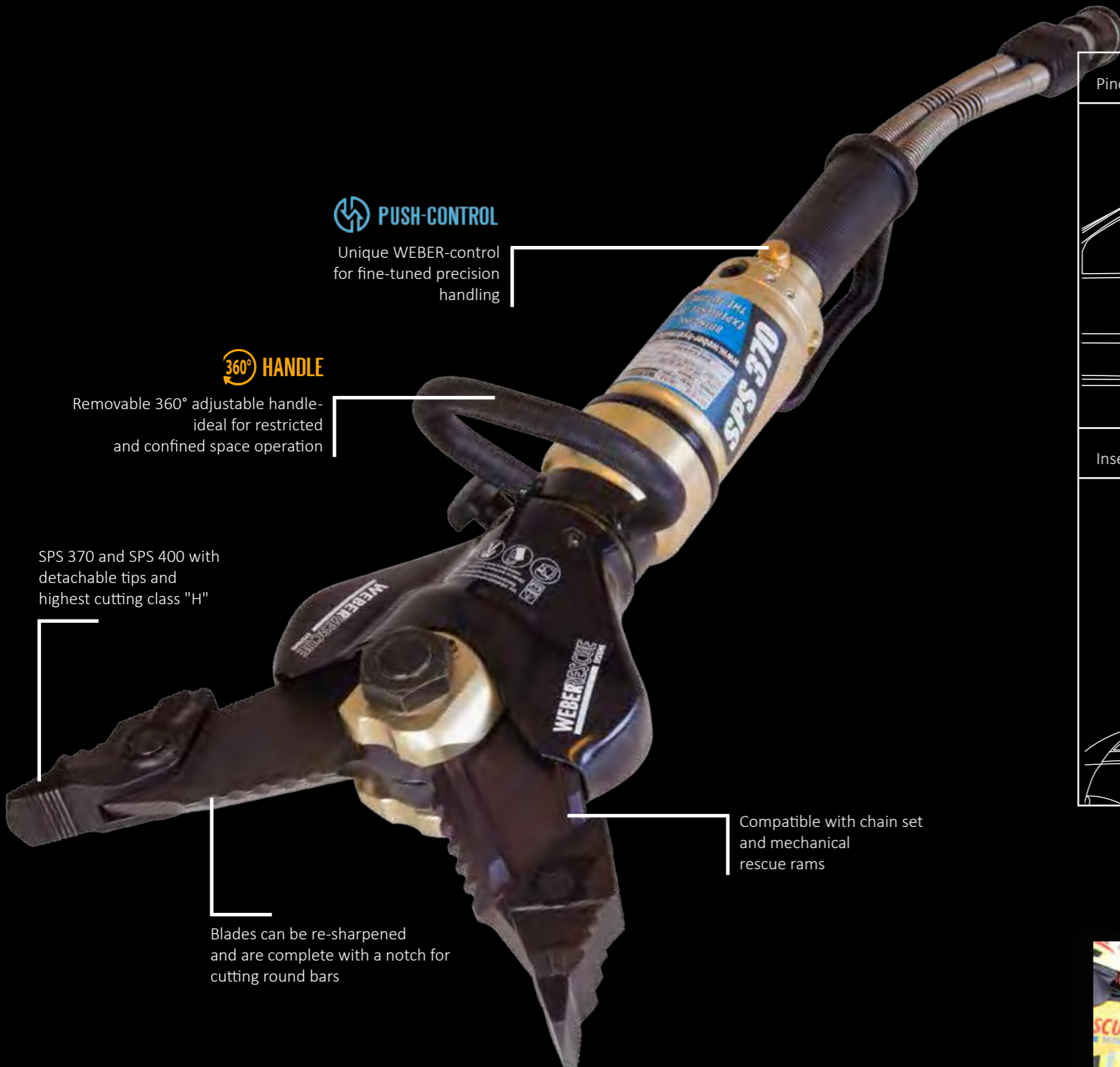

**PUSH-CONTROL**

Unique WEBER-control for fine-tuned precision handling

**360° HANDLE**

Removable 360° adjustable handle - ideal for restricted and confined space operation

SPS 370 and SPS 400 with detachable tips and highest cutting class "H"

Blades can be re-sharpened and are complete with a notch for cutting round bars

Compatible with chain set and mechanical rescue rams

# TIPS AND TRICKS MAKING A GAP

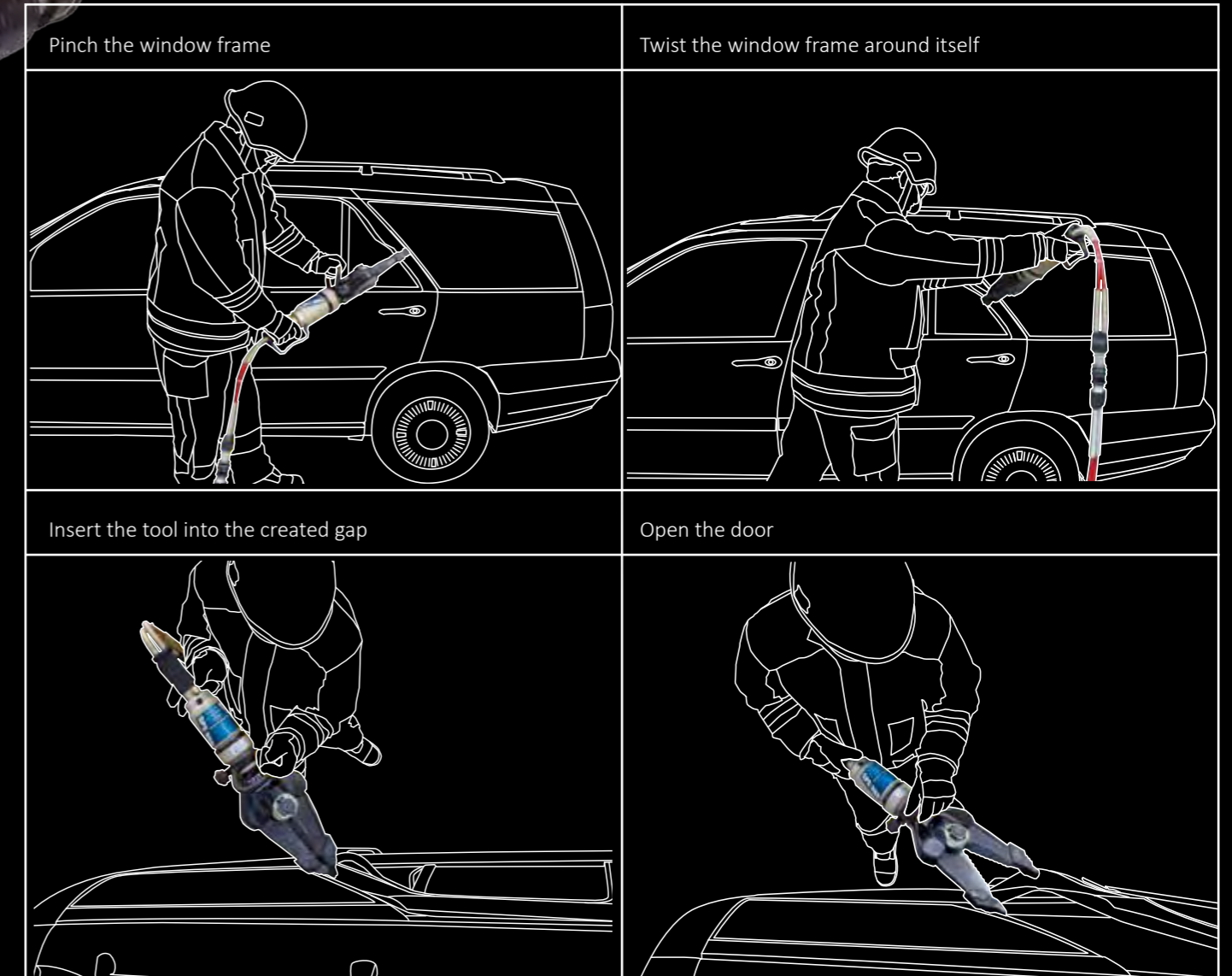

# COMBI TOOLS

**NEW!**

	SPS 270 MK2	SPS 360 L	SPS 370	SPS 400
Spreading distance	270 mm	360 mm	370 mm	420 mm
Spreading force in working range*	35-591 kN	37-783 kN	37-783 kN	36 - 1,071 kN
Max. cutting force*	33 t/324 kN	50 t/491 kN	50 t/491 kN	82 t/822 kN
Pulling force (with pulling device)	39 kN	52 kN	52 kN	98 kN
Pulling width (with pulling device)	380 mm	440 mm	390 mm	402 mm
Weight	9.7 kg	14.9 kg	16.0 kg	18.3 kg
EN class	BK 31/270-G-9,7	CK 37/360-H-14,9	CK 37/370-H-16,0	CK 36/400-I-18,3
Cutting performance (EN 13204)	1H-2G-3G-4H-5G	1I-2J-3H-4K-5J	1I-2J-3H-4J-5I	1J-2K-3I-4K-5K
NFPA class	A6/B7/C6/D7/E7	A7/B8/C7/D8/E8	A7/B8/C6/D8/E7	A7/B9/C7/D9/E9
Part no.	1086140	1062580	1063314	5931134

\*according to EN 13204 to 700 bar



**SPS 370 and SPS 400 with detachable tips!**



**NEW!**



## HAND-VARIO SPS 270 H

Manual powered combitool with integrated hydraulic drive

- Small space required for storage
- Agile handling
- Light weight
- Head can be rotated to any position within 360°

Opening	270 mm
Spreading force in working range	32 - 534 kN
Max. cutting force	30 t/292 kN
Pulling force (with pulling device)	35 kN
Pulling width (with pulling device)	380 mm
Weight	9.8 kg
EN class	BK 26/270-G-9,8
Cutting performance (EN 13204)	1H-2G-3G-4H-5G
DIN class (DIN 14751-4)	K 25 G-M
NFPA class	A6/B6/C6/D7/E7
Part no.	1084065

## ACCESSORIES

<b>Replacement (arm)</b>	
SPS 270 MK2 and SPS 270 H	1084095
SPS 360 L	1068993
SPS 370	1063315
SPS 400	1810499
<b>Pulling device, with pin for fastening the chains on the blades (arms). 2 pieces required</b>	
SPS 270 MK2 and SPS 270 H	2096617
SPS 360 L	2835746
SPS 370 and SPS 400	2836033
<b>Chain set</b>	
SPS 270 MK2	571407
SPS 360 L, SPS 370, SPS 400 and SPS 270 H	2819139
<b>Spreader tip</b>	
SPS 370 and SPS 400	3867323
<b>Rescue ram RZM 740</b>	
SPS 270 H, SPS 270 MK2 and SPS 360 L	1056478



# PASSION MEETS DYNAMICS

Pushing up to extended length of 1,600 mm



Unique WEBER-control for fine-tuned precision handling

Cylinder can be turned under load due to rotating pushing head

Piston rods with hard chrome-plated finish

Optimal length graduation - high power, less weight

# RESCUE RAMS WITH INTEGRATED REMAINING LENGTH MARKING

## The new rams - always see the remaining length!



All future rescue rams from WEBER RESCUE will have laser-etching on the piston rod to indicate the rams' remaining extension length.

This early warning system enables you to decide right away whether the ram you are currently using is long enough for the job or whether a longer ram must be prepared and used. A real time saver at work!

There are four etched lines around the circumference which indicate the remaining length. Each line has Centimetre and Inch markings which can be clearly seen from all angles. They show the last available 20 centimetres and so help you to select the right rescue ram.

A real plus for rescue work!

**NEW!**

**PATENT PENDING**

Remaining length marks laser-etched every 5 cm (2 in) on the piston rod

Indicates the last 20 centimetres until full extension

Up to four circumferential rings depending on type of cylinder

Inch and Centimetre markings around Piston rod

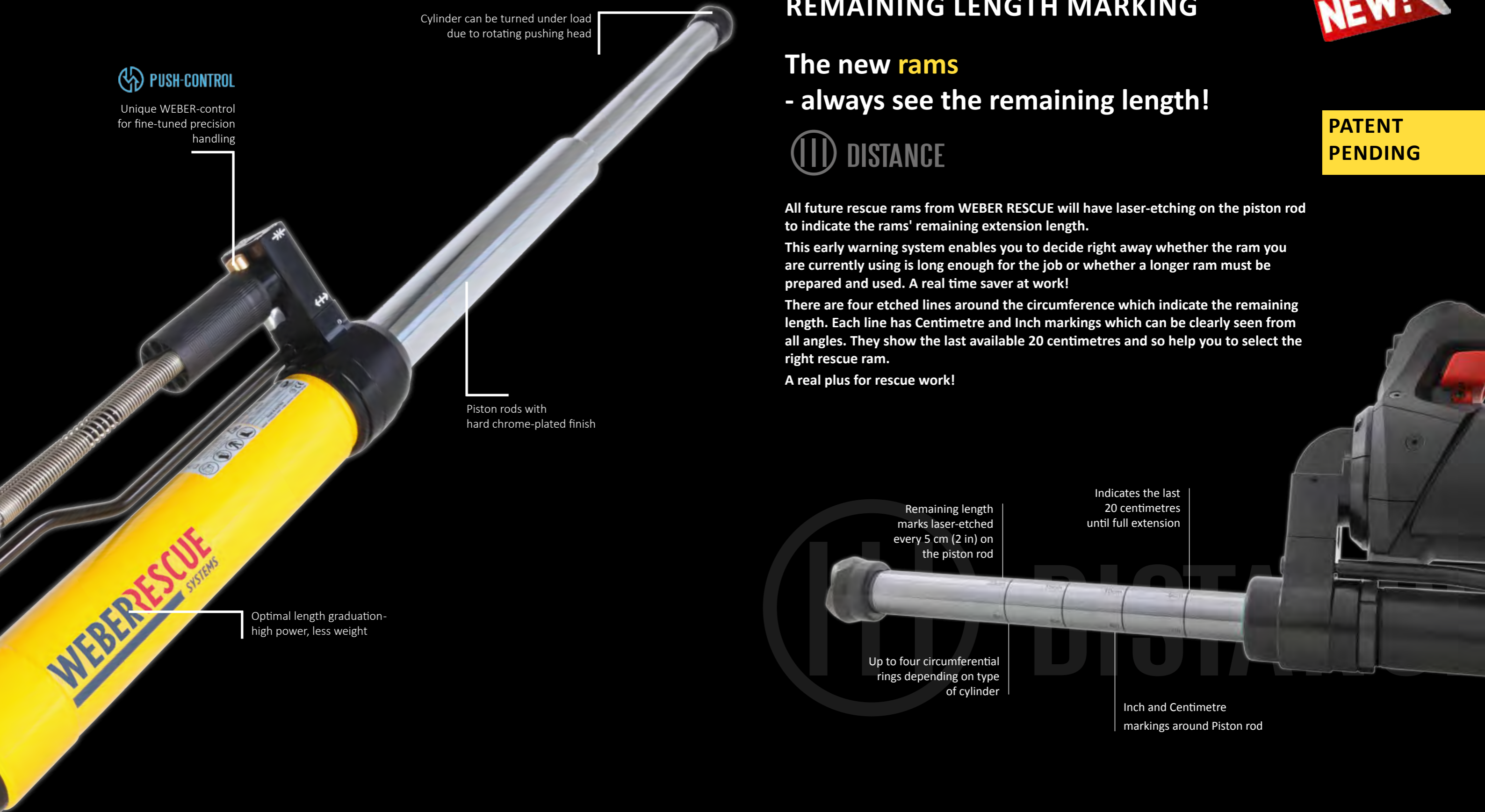

# RESCUE RAMS

## RESCUE RAMS SINGLE-STAGE

	RZ 1 – 850	RZ 2 – 1290	RZ 3 – 1640
Pushing force*	137 kN	137 kN	137 kN
Pulling force*	24.1 kN	24.1 kN	24.1 kN
Closed length	530 mm	750 mm	1,100 mm
Piston stroke	320 mm	540 mm	540 mm
Extended length	850 mm	1,290 mm	1,640 mm
Weight	11.7 kg	16.4 kg	19.4 kg
EN class	R 137/320-11,7	R 137/540-16,4	R 137/540-19,4
Part no.	5933803	5933781	5933765

## TELESCOPIC RESCUE RAMS

	RZT 2 – 600	RZT 2 – 775	RZT 2 – 1170	RZT 2 – 1500
Pushing force*	189.4/99 kN	189.4/99 kN	189.4/99 kN	189.4/99 kN
Closed length	300 mm	395 mm	540 mm	650 mm
Piston stroke	300 mm	380 mm	630 mm	850 mm
Extended length	600 mm	775 mm	1,170 mm	1,500 mm
Weight	9.3 kg	11.5 kg	15.2 kg	18.0 kg
EN class	TR 189/165-99/135-9,3	TR 189/210-99/170-11,5	TR 189/360-99/270-15,2	TR 189/470-99/380-18,0
Part no.	5936934	5931401	1050149	1050041

## TELESCOPIC RESCUE RAMS XL

	RZT 2 – 1500 XL	RZT 3 – 1310 XL
Pushing force*	269,4/129,5 kN	269,4/129,5/45,4 kN
Closed length	650 mm	480 mm
Piston stroke	852 mm	830 mm
Extended length	1,502 mm	1,310 mm
Weight	20.9 kg	17.2 kg
EN class	TR 269/445-130/407-20,9	–
Part no.	5932025	5934133

\*according to EN 13204 to 700 bar

## CROSSRAMMER RZ 1-1810

Perfect ram to enlarge a deformed interior and to work inside a vehicle!

- Lightweight and compact
- Body with small diameter
- Large extended length of 1,810 mm



Pushing force	36.44 kN
Closed length	990 mm
Piston stroke	820 mm
Extended length	1810 mm
EN class*	R 36/820-13,7
Weight	13.7 kg
Part no.	1077052

\*clearance certificate according to EN 13204

## ACCESSORIES

	Weight	Part no.
Base support front	6.0 kg	1824333
Base support back	9.8 kg	1824341
Sill support	10.0 kg	8121737
Rim adapter set back wheel (Base plate, 3 rim adapters and carrying case)	19.6 kg	2852144
Rim adapter set back and front wheel (Base plate, 3 rim adapters, rim adapter front and carrying case)	30.7 kg	2854082
Chain set for RZ 1-3 and for SP 30/35/35 L	7.4 kg	571407
Chain set for RZ 1-3 and for SP 43 XL/49/60	13.8 kg	2819139
Adapter for chain set 571407 (2 pcs. required)	0.7 kg	3837300
Adapter for chain set 2819139 (2 pcs. required)	0.8 kg	3847900
Accessory set RZ 1,2 and 3 (Different pushing heads with storage box)	6.5 kg	1083316
Extension 250 mm for RZT 2-600 and RZT 2-775	3.4 kg	3864588
Extension 175 mm for RZ 1-850	2.0 kg	1058482
Extension 250 mm for RZ 1-850	2.6 kg	3838579
Extension 320 mm for RZ 1-850	3.0 kg	1062442



# PASSION MEETS DYNAMICS

The new WEBER RESCUE E/V 70 W hydraulic power units



# TEAM gold

Power meets speed

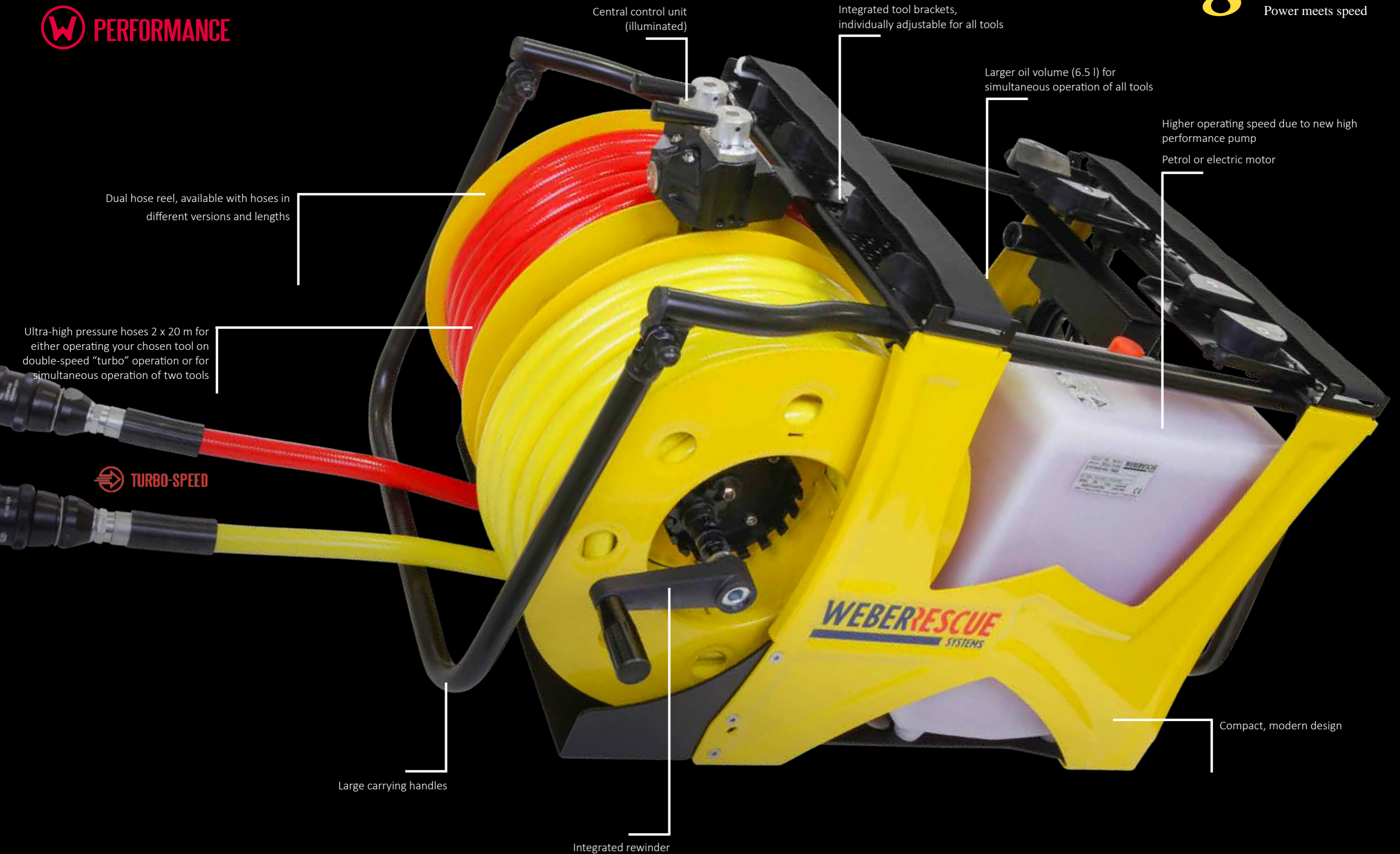

Central control unit (illuminated)

Integrated tool brackets, individually adjustable for all tools

Larger oil volume (6.5 l) for simultaneous operation of all tools

Higher operating speed due to new high performance pump

Petrol or electric motor

Dual hose reel, available with hoses in different versions and lengths

Ultra-high pressure hoses 2 x 20 m for either operating your chosen tool on double-speed "turbo" operation or for simultaneous operation of two tools



Large carrying handles

Integrated rewinder

Compact, modern design

# TURBO-SHIFTING

Shift position 1:  
Simultaneous operation

Shift position 2:  
TURBO mode = double speed

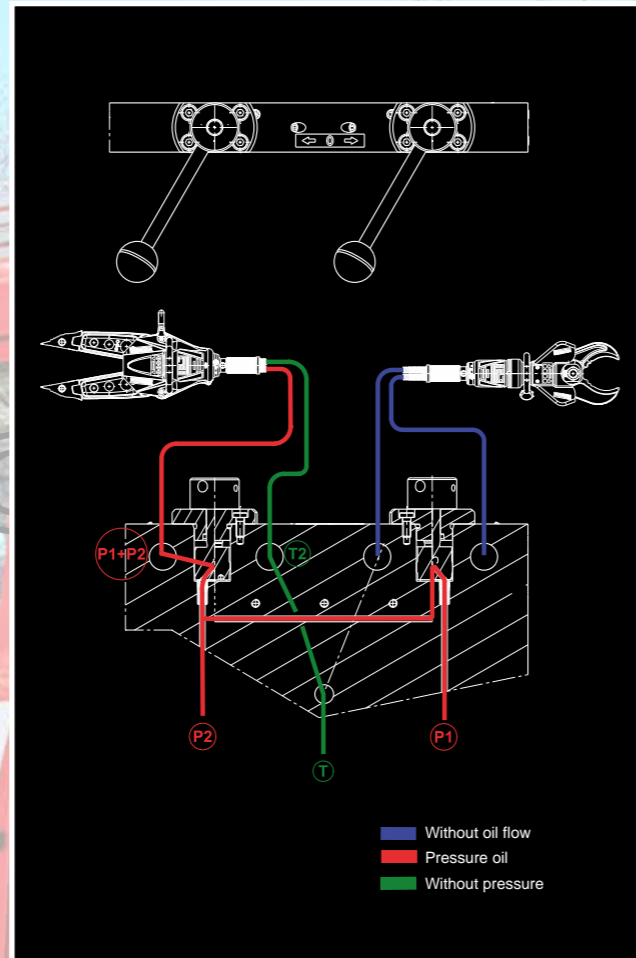
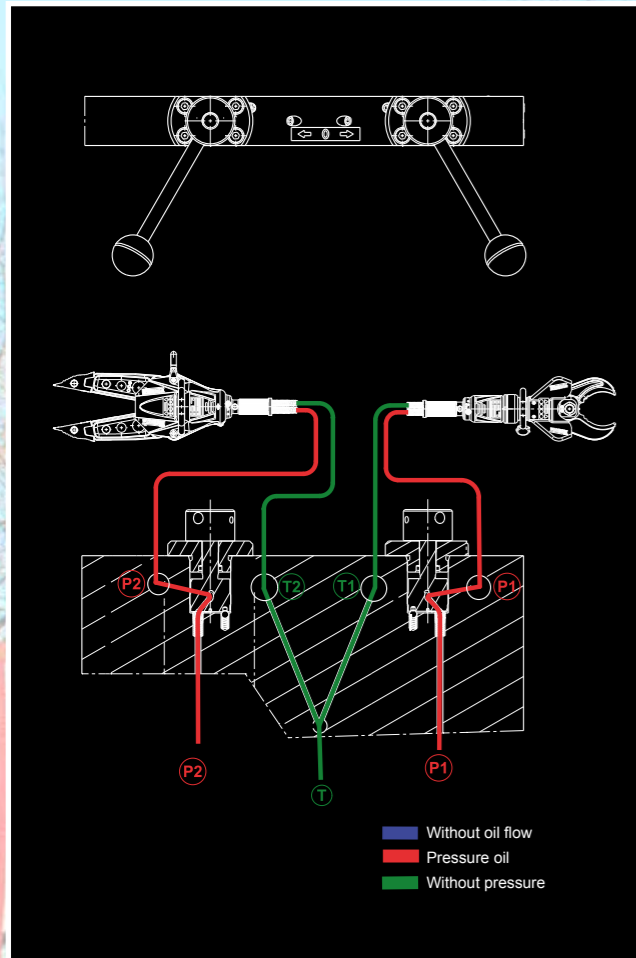

# TURBO-SPEED

# POWER UNITS



**E 70 W-SAH 20**  
**V 70 W-SAH 20**

Motor	E-Motor 230 V, 50 Hz, 2 kW	4-stroke petrol engine, 4 kW
Nominal pressure*	630/700 bar	630/700 bar
Oil volume	6.5 l	6.5 l
Weight	74.2 kg	75.9 kg
EN class	ATO/MTO	ATO/MTO
Part no.	1078718	1078719



**E 70 W-SAH 20**  
**V 70 W-SAH 20**  
**WITH COAX HOSES**



Motor	E-Motor 230 V, 50 Hz, 2 kW	4-stroke petrol engine, 4 kW
Nominal pressure*	630/700 bar	630/700 bar
Oil volume	6.5 l	6.5 l
Weight	73.0 kg	76.5 kg
EN class	ATO/MTO	ATO/MTO
Part no.	1069283	1058332



\*according to EN 13204 to 700 bar

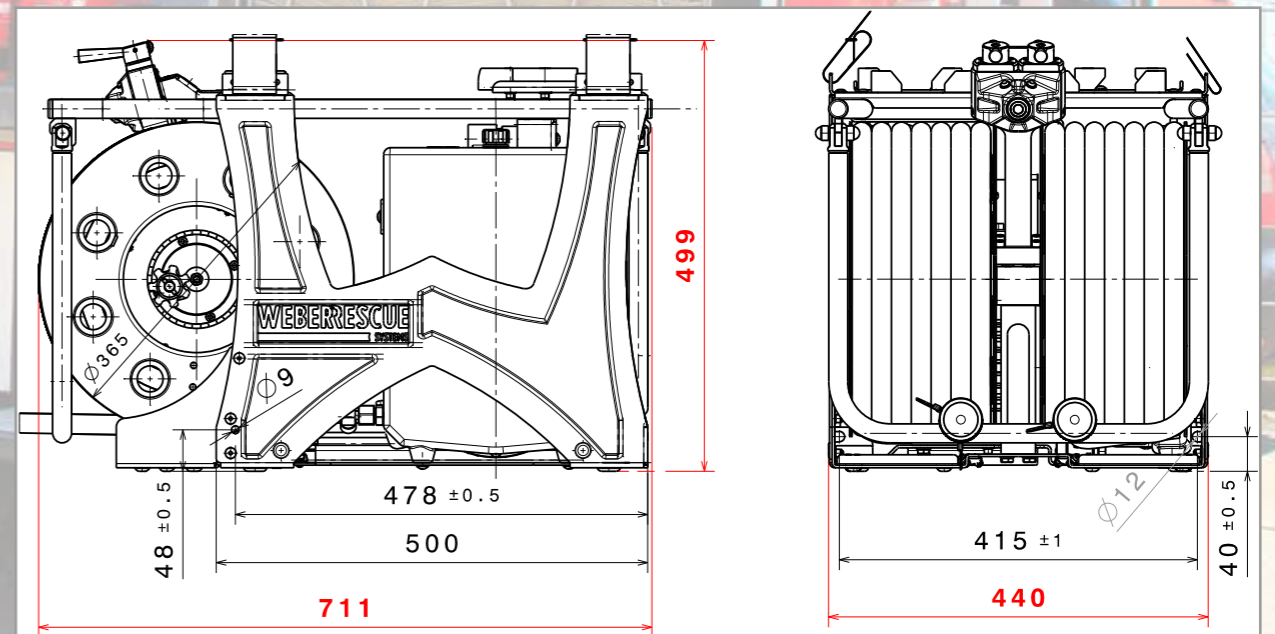

# FULL POWER MEETS MINIMUM SPACE

Compact power units with ECO technology



Operation of 2 tools simultaneously or one tool on "fast" turbo mode (more oil volume for faster working)

Industrial motor



Small, lightweight and flexible, high output – fast working

Will function even when under extreme inclination (up to 30°)

Automatic speed control to reduce noise



# TIPS AND TRICKS RESCUE OPENING

Original state	Apply spreader
create rescue opening	Enlarge rescue opening with rescue ram



# COMPACT POWER UNITS



## V 400 ECO ECO

	V 400 S	V 400 ECO
Motor	4-stroke petrol engine 1.5 kW	4-stroke petrol engine 1.5 kW
Nominal pressure*	630/700 bar	630/700 bar
Oil volume	2.5 l	2.5 l
Weight	17.3 kg	17.3 kg
EN class	STO	STO
Part no.	5934753	5936853



## V 50 ECO

## V / E 50 S ECO

	V 50 ECO	V 50 S	E 50 S
Motor	4-stroke petrol engine 2.2 kW	4-stroke petrol engine 3.4 kW	E-Motor 230 V, 50 Hz, 1.3 kW
Nominal pressure*	630/700 bar	630/700 bar	630/700 bar
Oil volume	4.0 l	4.0 l	4.0 l
Weight	29.8 kg	31.4 kg	33.5 kg
EN class	ATO/MTO	ATO/MTO	ATO/MTO
Part no.	5935717	5934460	1070365



## E-COMPACT

Motor	E-Motor 230 V, 50 Hz, 1.5 kW
Nominal pressure*	630/700 bar
Oil volume	2.8 l
Weight	12.5 kg
EN class	STO
Part no.	1050354

- Extremely lightweight and flexible
- One connection with very high output
- Small installation dimension



### ECO power

Engine revs are automatically increased when the tool control button is pressed. Returns to idle revs automatically when control button is released.

\*according to EN 13204 to 700 bar

## MORE COMPACT POWER UNITS...



### V-ECOSILENT

Motor	4-Stroke Petrol Engine 2.2 kW
Nominal pressure*	630/700 bar
Oil volume	2.7 l
Weight	24.9 kg
EN class	ATO/MTO
Part no.	5935318

- Extra silent - only 63.9 dB (A)



### V-ECOCOMPACT

Motor	4-Stroke Petrol Engine 2.2 kW
Nominal pressure*	630/700 bar
Oil volume	3.8 l
Weight	23.7kg
EN class	ATO/MTO
Part no.	1060793

- Small, strong, lightweight



\*according to EN 13204 to 700 bar



You can find our battery tools on page 40





# HOSES



## EXTENSION HOSES AND COUPLINGS

- High pressure dual extension hoses
- Filled with oil, fitted with SINGLE couplings

Length	Part no. yellow	Part no. red	Weight
5 m	2847647	2847639	4.3 kg
10 m	2847663	2847655	7.6 kg
15 m	2847680	2847671	9.5 kg
20 m	2847701	2847698	13.0 kg



## COAX HOSES

- COAX design hose (Hose-in-hose-system)
- Filled with oil, fitted with SINGLE couplings
- No twisting possible



Length	Part no. yellow	Part no. red	Weight
5 m	1052602	1052605	3.3 kg
10 m	1052603	1052606	5.5 kg
15 m	1052604	1052607	7.7 kg
20 m	1053457	1053455	10.0 kg



# HOSE REELS

## FREE STANDING DUAL HOSE REEL HF 20 T

- With carrying frame, complete with 2 x 20 m high-pressure hoses
- Both reels can be operated separately, even when the hoses are under pressure
- With two folding handles for rewinding



	Twin hose	COAX-hose
Weight	40.0 kg	34.0 kg
Part no.	5935016	1054768



## FREE STANDING SINGLE HOSE REEL EHF 20 T

- With carrying frame, complete with 20 m high-pressure hose
- Can be operated even when the hose is under pressure
- Folding handle for rewinding



	Twin hose	COAX-hose
Weight	20.5 kg	18.5 kg
Part no. high pressure hose red	5931932	1054236
Part no. high pressure hose yellow	5932491	1054754
Part no. high pressure hose blue	5932661	1055333
Part no. high pressure hose black	5932980	--



## HOSE PROTECTION

- Additional protection tools pig tail hoses
- KEVLAR material protective coating and duraskin® cover
- For tool control valves with plastic sleeve
- Velcro fastener

Color	black
Length	30 cm
Part no.	8064563

## PROTECTION COVER

- For 5-20 m Hoses
- For protection against abrasion and contamination
- KEVLAR material protective coating and duraskin® cover
- Velcro fastener

Color	red	yellow	blue
Length	4 m	4 m	4 m
Part no.	8051496	8051500	8058024



## Comparison common coupling/ SINGLE coupling



- Common coupling:**
- 2 actions for coupling
  - Coupling only without pressure possible
  - Pressure relief plug needed

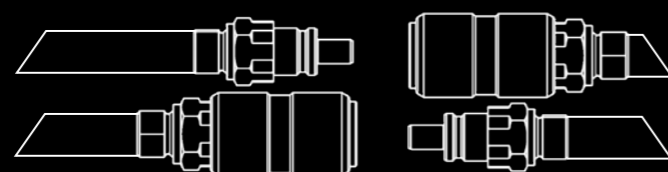

Common coupling can be replaced with SINGLE coupling

- + SINGLE coupling:**
- 1 action for coupling
  - Coupling with pending pressure
  - No need for any kind of pressure relief plug

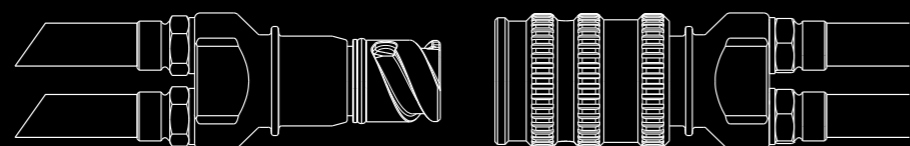

# THE NEW MOBILITY

## E FORCE 2



Long operating time due to 5.0 Ah capacity (28 V Li-Ion-Battery)

Rocker switch for fine tuned handling even with one hand

LED lights for better view in the working area



Fibre-reinforced case for hardest use

Drive unit retrofittable for E-Force tools Generation 1 and mobile rescue tools

New, efficiency improved drive unit for longer working time and higher operating speed

# NEW BATTERY TOOL SERIES E-FORCE 2



- New housing with efficiency improved drive unit
- Nearly double working time
- Additionally higher operating speed

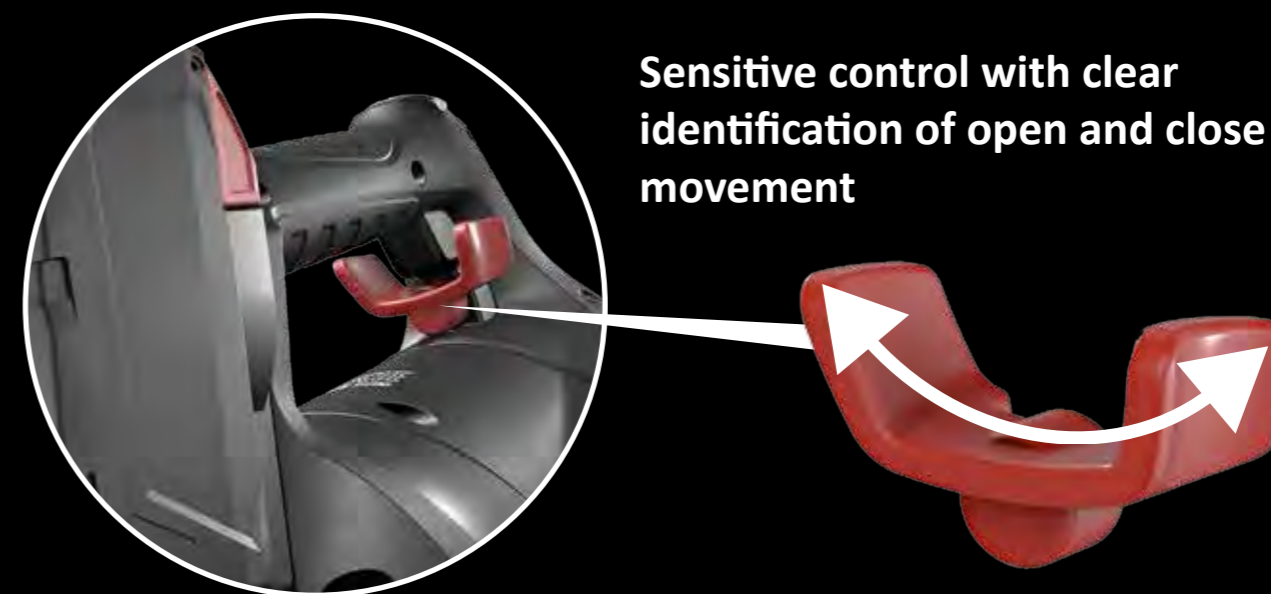



**Batteries not  
included in delivery!**

## BATTERY TOOLS

### CUTTERS E-FORCE 2

	RSX 160-50 E-FORCE 2	RSU 180 PLUS E-FORCE 2	RSU 210 PLUS E-FORCE 2
Opening	160 mm	180 mm	210 mm
Weight (incl. battery)	18.6 kg	20.4 kg	23.5 kg
EN class	BC 160-H-18,6	BC 180-H-20,4	CC 200-K-23,5
Cutting performance (EN 13204)	1I-2K-3H-4J-5H	1J-2K-3K-4K-5K	1K-2K-3K-4K-5K
NFPA class	A7/B8/C6/D7/E8	A8/B9/C7/D9/E9	A8/B9/C8/D9/E9
Part no.	1077690	1082343	1087781



### COMBI TOOLS E-FORCE 2

	SPS 270 MK 2 E-FORCE 2	SPS 360 L E-FORCE 2	SPS 370 E-FORCE 2
Spreading distance	270 mm	360 mm	370 mm
Spreading force	35 - 591 kN	37 - 783 kN	37 - 783 kN
Max. cutting force	33 t/ 324 kN	50 t/ 491 kN	50 t/ 491 kN
Pulling force (with pulling device)	39 kN	52 kN	52 kN
Pulling width (with pulling device)	380 mm	440 mm	390 mm
Weight (incl. battery)	13.6 kg	18.9 kg	19.9 kg
EN class	BK 31/270-G-13,6	CK 37/360-H-18,9	CK 37/370-H-19,9
Cutting performance (EN 13204)	1H-2G-3G-4H-5G	1I-2J-3H-4K-5I	1I-2I-3H-4J-5I
NFPA class	A6/B7/C6/D7/E7	A7/B8/C7/D8/E8	A7/B8/C6/D8/E7
Part no.	1087085	1074458	1077676



## BATTERY TOOLS

**E-FORCE 2**

### Spreaders E-FORCE 2

	SP 35 AS E-FORCE 2	SP 53 BS E-FORCE 2
Spreading force	35 - 171 kN	53 - 421 kN
Closing force	76 kN	100 kN
Spreading distance	600 mm	800 mm
Weight (incl. battery)	18.3 kg	24.2 kg
EN class	AS 35/600-18	BS 53/800-24,2
Part no.	1075263	1077791



SP 35 AS E-FORCE 2

SP 53 BS E-FORCE 2

**NEW!**

### Rescue ram E-FORCE 2

	RZ 1-910 E-FORCE 2	RZT 2-1360 E-FORCE 2	RZT 2-1500 E-FORCE 2
Pushing force	111.3 kN	108/62 kN	108/62 kN
Closed length	540 mm	586 mm	700 mm
Piston stroke	368 mm	800 mm	800 mm
Extended length	908 mm	1,386 mm	1,500 mm
Weight (incl. battery)	15.7 kg	20.1 kg	21.4 kg
Part no.	1075272	1078342	1081519



RZ 1-910 E-FORCE 2



RZT 2-1360 E-FORCE 2



RZT 2-1500 E-FORCE 2

## SPECIALISED BATTERY TOOLS

**E-FORCE 2**

### Power wedge SPK 250 E-FORCE 2

Insertion height	8 mm
Max. lifting height	61 mm
Lifting force	25 t / 245 kN
Weight (incl. battery)	12.6 kg
Part no.	1077812



### Door opener DO 140 E-FORCE 2

Piston stroke	140 mm
Pushing force*	11 t / 105 kN
Weight (incl. battery)	12.9 kg
Part no.	1078140



### Concrete crusher BC 250 E-FORCE 2

Opening	250 mm
Closing force	11 t/109 kN
Weight (incl. battery)	21.5 kg
Part no.	1077721



### Accessories

	Weight	Part no.
<b>Mechanical rescue ram</b> RZM 740 for SPS 270 MK2 E-FORCE 2 and SPS 360 L E-FORCE 2	6.9 kg	1056478
<b>Chain set</b> for SPS 270 MK2 E-FORCE 2	7.4 kg	571407
for SP35 AS/SPS 360 L/SPS 370 E-FORCE 2	13.8 kg	2819139
for SP 53 BS E-FORCE 2	13.8 kg	571415
<b>Pulling device</b> (2 pcs. required) for SPS 270 MK2 E-FORCE 2	1.4 kg	2096617
for SPS 360 L E-FORCE 2	1.4 kg	2835746
for SPS 370 E-FORCE 2	1.4 kg	2836033
<b>Extension for</b> RZ 1-910 E-FORCE 2		
175 mm	2.0 kg	1058482
250 mm	2.6 kg	3838579
320 mm	3,0 kg	1062442



# BATTERY POWER UNITS



Both battery power units now with ECO drive!



## B-COMPACT ECO

- The advantages of the successful power unit E-COMPACT in combination with battery power!
- Extremely lightweight and flexible
- Up to 10 hours run-time in ECO mode
- Small stowage dimension
- Ability to connect 2 batteries
- Permanent operation by using a power supply
- Delivered without battery



Nominal pressure	630/700 bar
Oilvolume	2.8 l
Weight (oil-filled, incl. battery)	12.2 kg
Part no.	1081742

## BATTERY PAC ECO

- Extremely lightweight hydraulic power unit with 28 V battery drive
- Up to 10 hours run-time in ECO mode
- Back-pack solution with wide and comfortable belts for safe fit
- Nominal pressure and tank volume constructed to drive all WEBER rescue tools (including XL rescue rams)
- Supplied without batteries as standard, 2nd battery optional to double the operation time (10 Ah)



Nominal pressure	630/700 bar
Oilvolume	2.5 l
Weight (oil-filled, incl. battery)	11.2 kg
Part no.	1081828

# ACCESSORIES BATTERY TOOLS



Battery compatible with MILWAUKEE battery-operated saws!

	Weight	Part no.
Spare battery 28 V / 3 Ah	1.0 kg	1053785
Spare battery 28 V / 5 Ah	1.0 kg	1072893
Battery pouch for one battery (without belt)	0.2 kg	1056921
Belt for battery pouch	0.1 kg	1056920
On-vehicle charger (without plug)	1.0 kg	1060423
Mains charger 110 V for one battery	0.8 kg	1054099
Mains charger 230 V for one battery	0.8 kg	1054097
Power supply 230 V	4.0 kg	1060422
Power supply 110 V	5.0 kg	1060426
Transport bag E-FORCE 2 for SPS 270, SPS 360 L, SPS 370, RSX 160-50, RSU 180 und SP 35 AS	1.8 kg	1058128
Set carrying strap (1 carrying strap + 1 fixation strap) for E-FORCE 2 tools	0.4 kg	1080657
Carrying strap	0.3 kg	1078259
Fixation strap	0.1 kg	1078261
Battery lightning LED Quicklight 28V Details see page 63	8.0 kg	1084044



# BATTERY SAWS



	Weight	Part no.
MILWAUKEE Reciprocating saw V 28 SET Recip saw tool, 2 batteries 28 V / 3 Ah, mains charger 230 V for one battery, carrying case	9.0 kg	1054063
MILWAUKEE Reciprocating saw tool V 28 without battery, mains charger and carrying case	3.0 kg	1059177
MILWAUKEE Metal cutting circular saw V 28 SET, 2 batteries 28 V / 3 Ah, mains charger 230 V for one battery, carrying case	9.2 kg	1078183
MILWAUKEE Metal circular cutting saw V 28 without battery, mains charger and carrying case	3.2 kg	1059178



# ACCESSORIES BATTERY SAWS

	Weight	Part no.
Blade EXTRICATION SET including rolled bag 4 pcs blades 150 mm / carbide tips 6 pcs blades 230 mm / carbide tips	2.0 kg	1078478
Blade EXTRICATION 150 mm	0.03 kg	1078476
Blade EXTRICATION 230 mm	0.05 kg	1078477
Roll up bag for blades EXTRICATION	0.12 kg	1081947
Blade SET DIN 5 pcs blades wood / plastic 230 mm 5 pcs blades wood 230 mm 5 pcs blades wood with nails 150 mm 5 pcs blades for metal 230 mm	0.3 kg	1059189 1059182 1059183 1059184 1059186
Blade SET VU 5 pcs blades for metal 150 mm 5 pcs blades for metal 230 mm 5 pcs blades universal 200 mm	0.2 kg	1059190 1059185 1059186 1059187
Circular saw blades	0.2 kg	1059188



# HOLSTER FOR RECIP SAW BLADES

- For mounting directly on the reciprocating saw (suits most models)
- Holds two reciprocating saw blades (short and long) up to 230 mm length
- A sewn wedge facilitates the removal of the saw blades
- Therefore replacement of blunt blades only takes a few seconds
- Integrated magnets hold the cover open
- A special gumming on the holster and straps ensures a perfect secure fit on the saw

Dimension (LxWxH)	250 x 50 x 15 mm
Weight (without blades)	70 g
Max. length of straps	300 mm
Distance of front strap	80 mm
Part no.	1083101



## LIGHT TOOLS

- Extremely lightweight and versatile
- Rescue tools for disasters, such as earthquakes and building collapses
- All tools weigh less than 10 kg
- All tools are matched to the power unit
- One-handed operation possible with tools
- Special transport system for usage in difficult terrain (e.g. helicopter transport)

### Cutters S 140-26 light

Opening	140 mm
Max. cutting force*	255 kN
EN class	AC-115-D-7,9
NFPA class	A5/B3/C4/D6/E7
Weight	7.9 kg
Part no.	1075652



S 140-26 light

### Combi tools SPS 270 light

Spreading distance	270 mm
Max. cutting force*	up to 48 t / 471 kN
Pulling force	39 kN
Cutting performance (EN 13204)	1H-2G-3G-4H-5G
EN class	BK31/270-G-8,9
NFPA class	A6/B7/C6/D7/E7
Weight	8.9 kg
Part no.	1086181



SPS 270 MK2 light

### Rescue ram light

	RZ 1-465 light	RZ 1-580 light
Pushing force*	111.3 kN	111.3 kN
Closed length	317 mm	395 mm
Piston stroke	150 mm	185 mm
Extended length	467 mm	580 mm
EN class*	R 111/150-7	R 110/185-9
Weight (incl. battery)	6.9 kg	8.7 kg
Part no.	1075651	1075944



RZ 1-465 light

We also offer an extensive range of pneumatic solutions!



### Power unit V 400 light

Motor	4-stroke petrol engine HONDA 1.2 kW
Nominal pressure	700 bar
Oil volume	1.5 l
Weight (oil-filled)	14.2 kg
Part no.	1075621

# STROKE MEETS CONTROL

*Tools for lifting, pushing and moving of loads*



Save transport and storage

Hydraulic door opener for rapid forcible entry and lifting of concrete slabs, steel beams etc.

Hand pump for independent operations

# TIPS AND TRICKS DOOR OPENING, FROM ABOVE

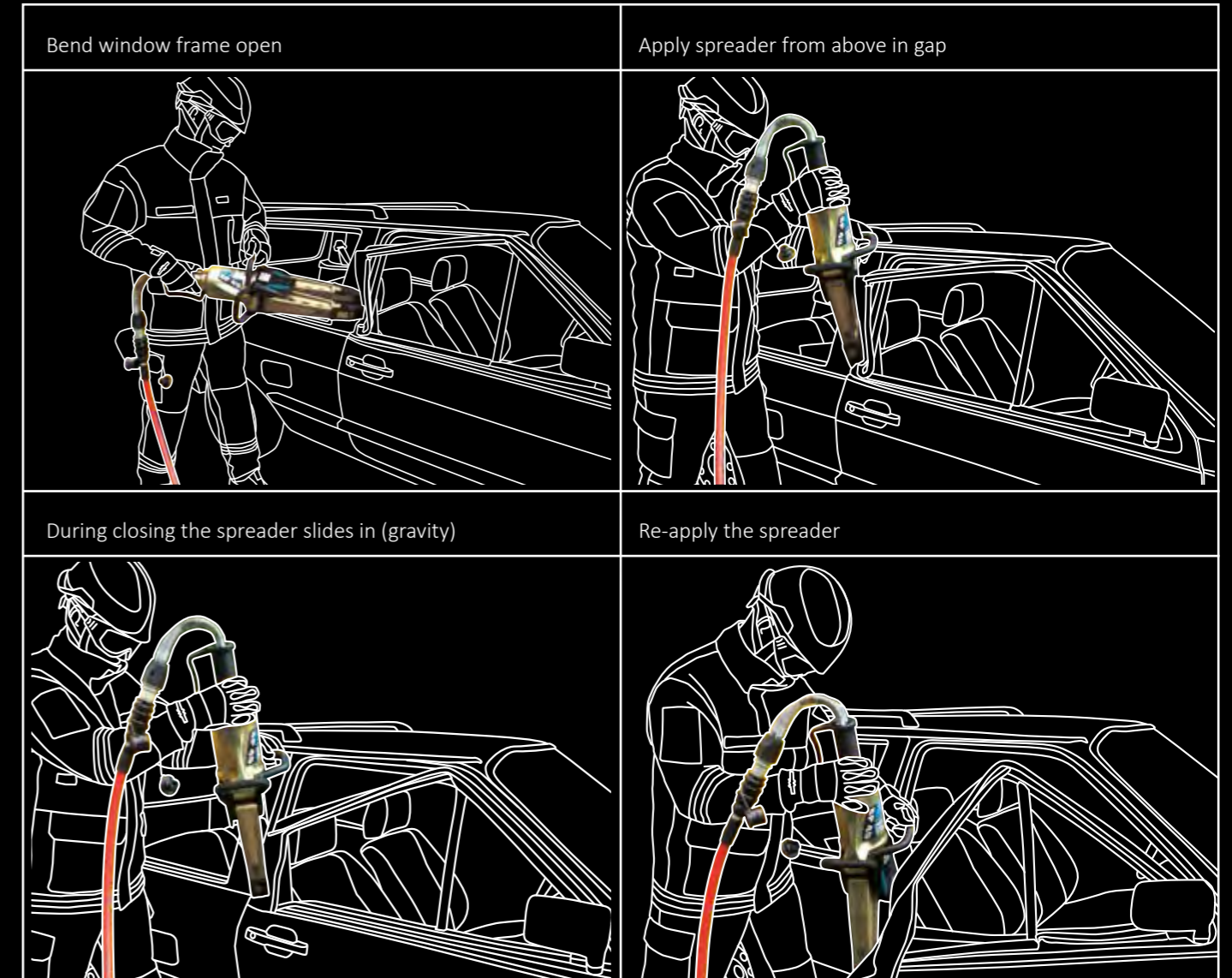



# LIFTING EQUIPMENT

## LIFTING SETS

- Single-acting hydraulic cylinders
- Lifting power 137 kN
- Including hand pump and accessories
- DIN 14800

	Lifting set 1	Lifting set 2
No. of cases	2	1
Weight	77.0 kg	51.0 kg
Part no.	5933552	5933544



Picture: Lifting set 2

## HYDRAULIC LIFTER SBH 15-255

- Precise hydraulic lifting and lowering
- Minimal set-up time
- Control unit MSE required
- EN 13204 and NFPA 1936 certified

Lifting force	148 kN
Lifting force claw	100 kN
Insertion height	39.5 mm
Piston stroke	255 mm
Weight	20.9 kg
Part no.	2839075



Connection lifter/MSE through extension hoses or hose reel with couplings without quickstop

## MOBILE CONTROL UNIT MSE 15-255

- simultaneous and independent operation of two lifters (1 pressure connection per lifter required)
- Safety steering according DIN 14751



Weight	8.6 kg
Part no.	2839440

## DOOR OPENING KIT

- For rapid forcible entry
- For lifting heavy objects (concrete slabs, steel beams etc.)
- Including hand pump, hose, door opener and transport case

Weight	17.9 kg
Part no.	1075344



## DOOR OPENER SINGLE ACTION

Lifting force	114.5 kN
Piston stroke	120 mm
Weight	7.1 kg
Part no.	1075922

\*according to EN 13204 to 700 bar

## BÜFFEL B 10

	<b>B 10</b>
Lifting force	98 kN
Total Insertion height	800 mm
Piston stroke	350 mm
Weight	38.5 kg
Part no.	198471

## ACCESSORIES

	<b>B 10</b>
Spherical base	4129881
Square base	4129873
Bearing plate	32255



# SPEED MEETS SAFETY

The improved stabilisation system STAB-FAST MK2

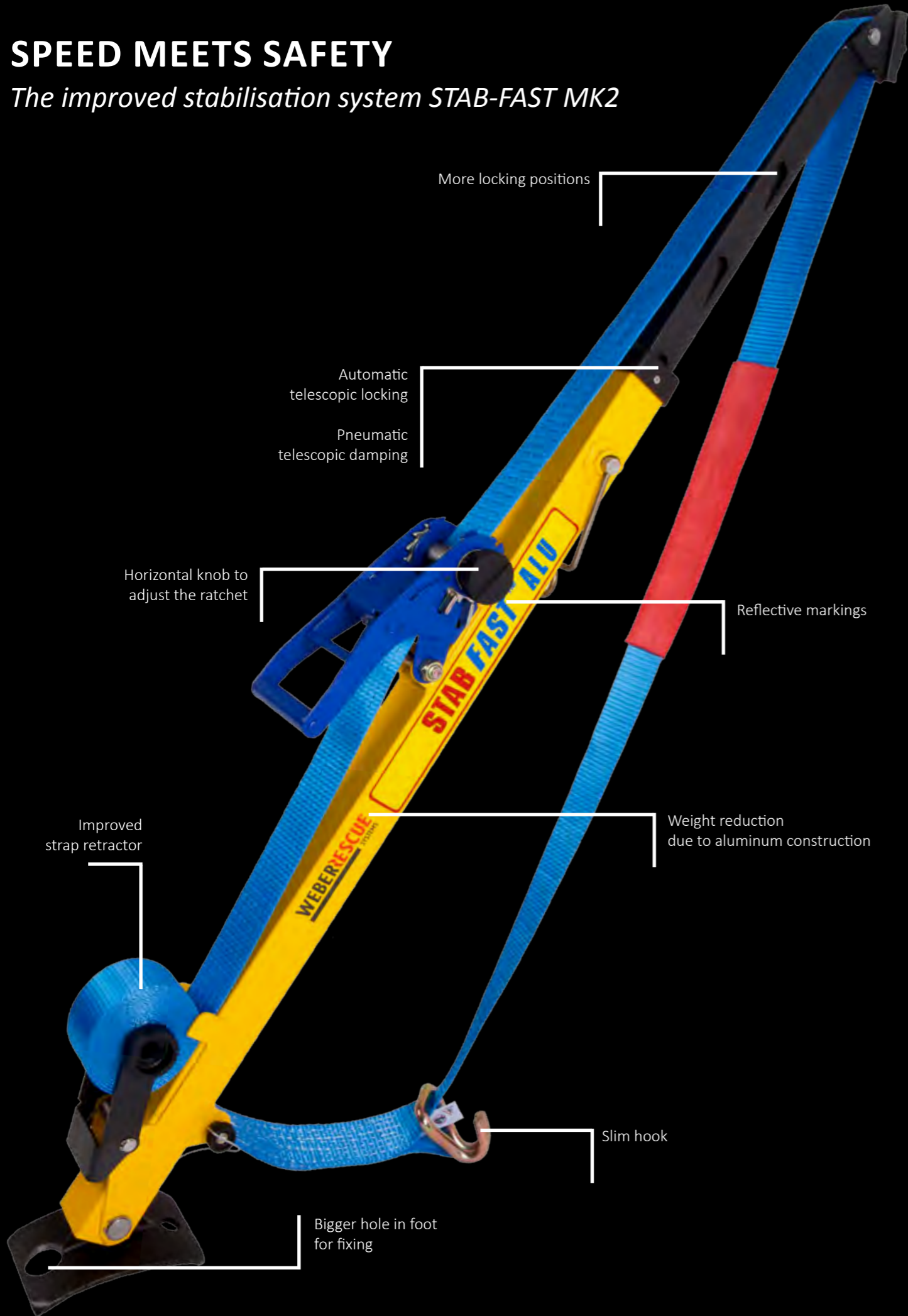

# TIPS AND TRICKS PULLING STEERING WHEEL

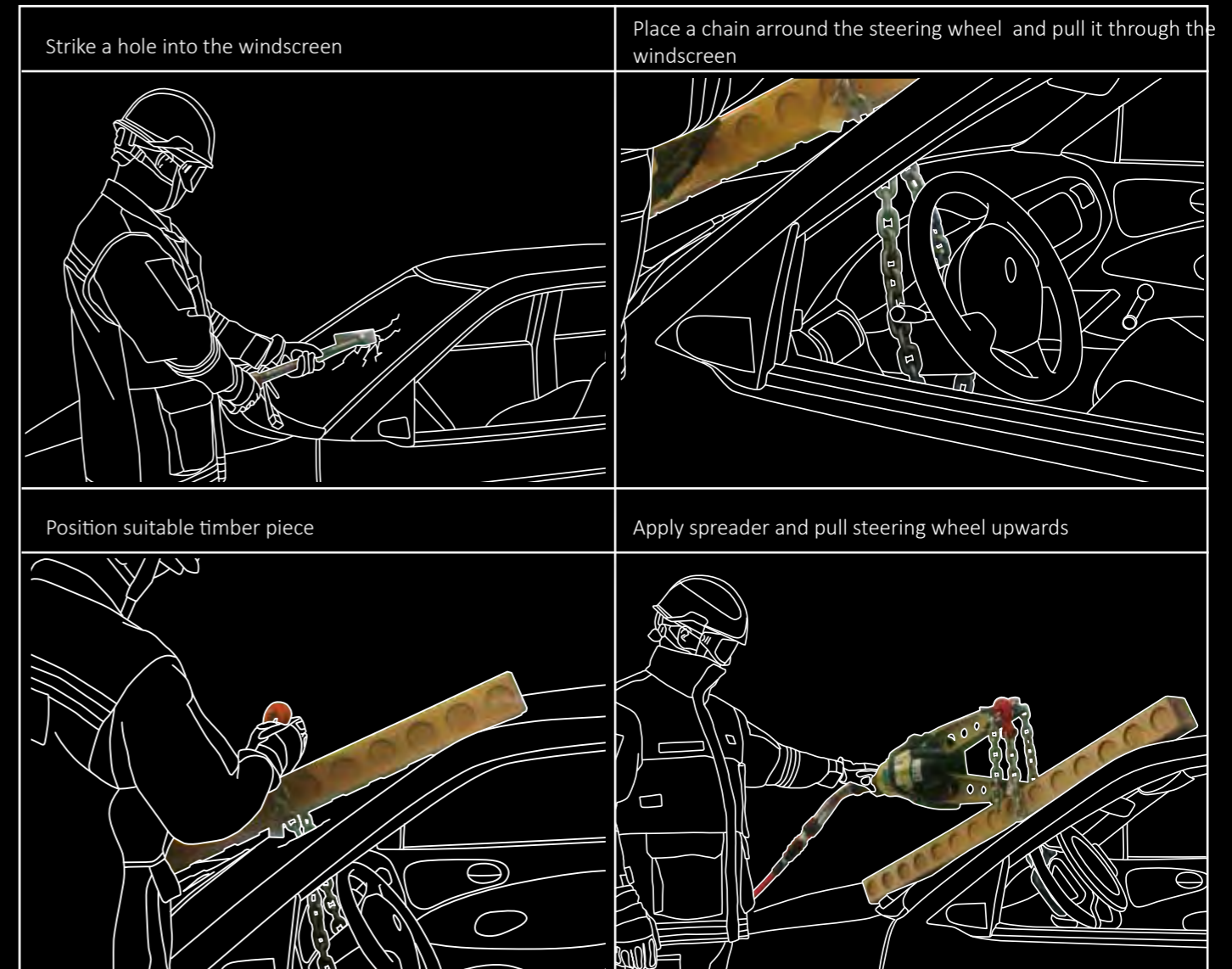

# STABILISATION

## STAB-FAST ALU

- TÜV and CE certified
- Easy, versatile and safe system
- Quick and easy installation



**The new STAB-FAST ALU!!**  
 Lighter due to aluminium construction  
 Improved knife



STAB FAST ALU

STAB FAST ALU Basic

STAB FAST ALU XL

	STAB-FAST ALU	STAB-FAST ALU Basic	STAB-FAST ALU XL
<b>Content</b>	3 struts, hook blade, wedge and 2 transport bags	2 struts, hook blade and transport bag	2 struts, hook blade and transport bag
<b>Closed length</b>	1,070 mm	1,070 mm	1,500 mm
<b>Extended length</b>	1,720 mm	1,720 mm	2,500 mm
<b>Weight per strut</b>	7.2 kg	7.2 kg	10.3 kg
<b>Maximum load in longitudinal direction of strut</b>	1,500 kg	1,500 kg	2,500 kg
<b>Length of strap</b>	5,000 mm	5,000 mm	10,000 mm
<b>Bag size</b>	1,100 x 300 x 120 mm	1,100 x 300 x 120 mm	1,600 x 500 x 180 mm
<b>Weight</b>	33.0 kg	19.0 kg	30.0 kg
<b>Part no.</b>	1078418	1078419	1078420

# STABILISATION

## STAB-PACK

- To stabilise the vehicle simply and precisely
- Safety due to easy handling
- Adjustable by two integrated wood wedges
- Safety due to large footprint

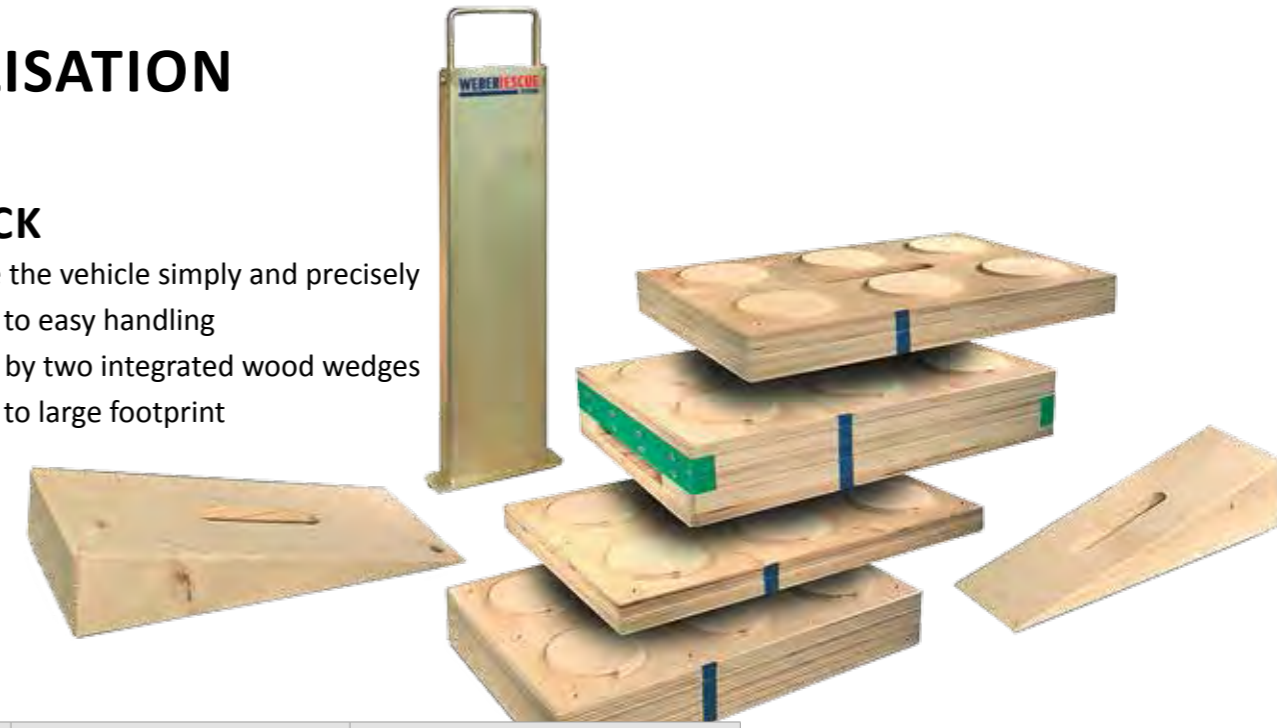

	STAB-PACK	STAB-PACK-SET
<b>Dimension</b>	270 x 180 x 310 mm	600 x 400 x 320 mm (4 pcs. in Eurobox)
<b>Weight</b>	8.6 kg	38.0 kg
<b>Part no.</b>	8044406	1052771



# MORE STABILISATION...

## STAB-LOCK-SET

- Water-proofed bonded beech plywood
- Similar to the Lego system
- Compatible to STAB-PACK system



Set	Dimensions	Weight	Part no.	Pcs.
<b>Eurobox</b>	600 x 400 x 320 mm	3.3 kg	1052769	1
<b>Baseplate 4 x 6</b>	540 x 360 x 36 mm	4.9 kg	1051857	1
<b>Wedge</b>	230 x 90 x 60 mm	1.5 kg	1051858	4
<b>Top 2 x 3</b>	270 x 185 x 22 mm	1.3 kg	1052594	2
<b>Top 2 x 3 s</b>	270 x 185 x 22 mm	1.1 kg	1051856	2
<b>4 square 2 x 3</b>	270 x 185 x 95 mm	3.0 kg	1051846	1
<b>4 square 2 x 6</b>	540 x 185 x 95 mm	6.4 kg	1051847	1
<b>4 square 1 x 3</b>	270 x 95 x 95 mm	1.5 kg	1051852	1
<b>4 square 1 x 3 s</b>	270 x 95 x 95 mm	1.4 kg	1051853	1
<b>4 square 1 x 6</b>	540 x 95 x 95 mm	3.1 kg	1051854	1
<b>4 square 1 x 6 s</b>	540 x 95 x 95 mm	3.0 kg	1051855	1
<b>Set-Nr. 1052770</b>		30.5 kg		

STAB-LOCK 2x3

STAB-LOCK 1x6s

STAB-LOCK Wedge

STAB-LOCK 1x12

STAB-LOCK 2x18

## ADDITIONAL PARTS STAB-LOCK

Type	Dimensions	Weight	Part no.
<b>4 square 1 x 9</b>	810 x 95 x 95 mm	4.4 kg	1052589
<b>4 square 2 x 9</b>	810 x 185 x 95 mm	8.6 kg	1051848
<b>4 square 1 x 12</b>	1,080 x 95 x 95 mm	5.4 kg	1052591
<b>4 square 2 x 12</b>	1,080 x 185 x 95 mm	11.4 kg	1051849
<b>4 square 1 x 15</b>	1,350 x 95 x 95 mm	7.4 kg	1052592
<b>4 square 2 x 15</b>	1,350 x 185 x 95 mm	14.8 kg	1051850
<b>4 square 1 x 18</b>	1,620 x 95 x 95 mm	9.0 kg	1052593
<b>4 square 2 x 18</b>	1,620 x 185 x 95 mm	17.2 kg	1051851

## STAB-FIX

- Recycled PE
- Durable and shatterproof
- Oil- and chemical resistant
- Maximum load capacity up to 110 kg/cm<sup>2</sup>
- No slipping because of pyramid design

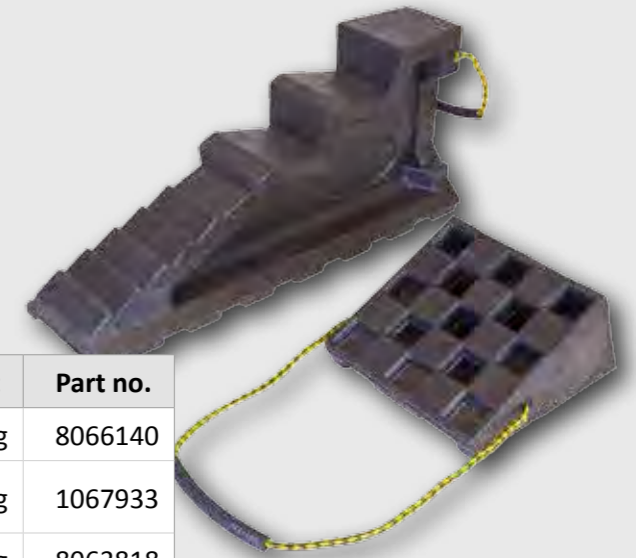

Type	Dimensions	Weight	Part no.
<b>Chock</b>	640 x 140 x 280 mm	7.4 kg	8066140
<b>Slide Step Chock</b>	620 x 170 x 275 mm	10.0 kg	1067933
<b>Block 25</b>	230 x 230 x 25 mm	1.4 kg	8063818
<b>Block 50</b>	230 x 230 x 50 mm	2.3 kg	8063826
<b>Block 75</b>	230 x 230 x 75 mm	3.4 kg	8063834
<b>Wedge 75</b>	215 x 75 x 80 mm	0.7 kg	3191796
<b>Wedge 150</b>	215 x 150 x 80 mm	1.3 kg	3191800
<b>4 square 100</b>	100 x 100 x 450 mm	3.1 kg	8137242
<b>4 square 150</b>	150 x 150 x 600 mm	9.0 kg	8138575
<b>Bag</b>		0.5 kg	8137250



**Just available in black!**



## STAB-FIX 4 SQUARE SET

- 9 plastic parts within one set
- With transport bag

<b>Stab-Fix 4 square 100 black</b>	9 pcs.
<b>Bag 300 x 300 x 450 mm</b>	1 pcs.
<b>Weight</b>	28.4 kg
<b>Part no.</b>	8139342



# STANDARD MEETS EXTRA

*Useful accessories for the rescue operation*

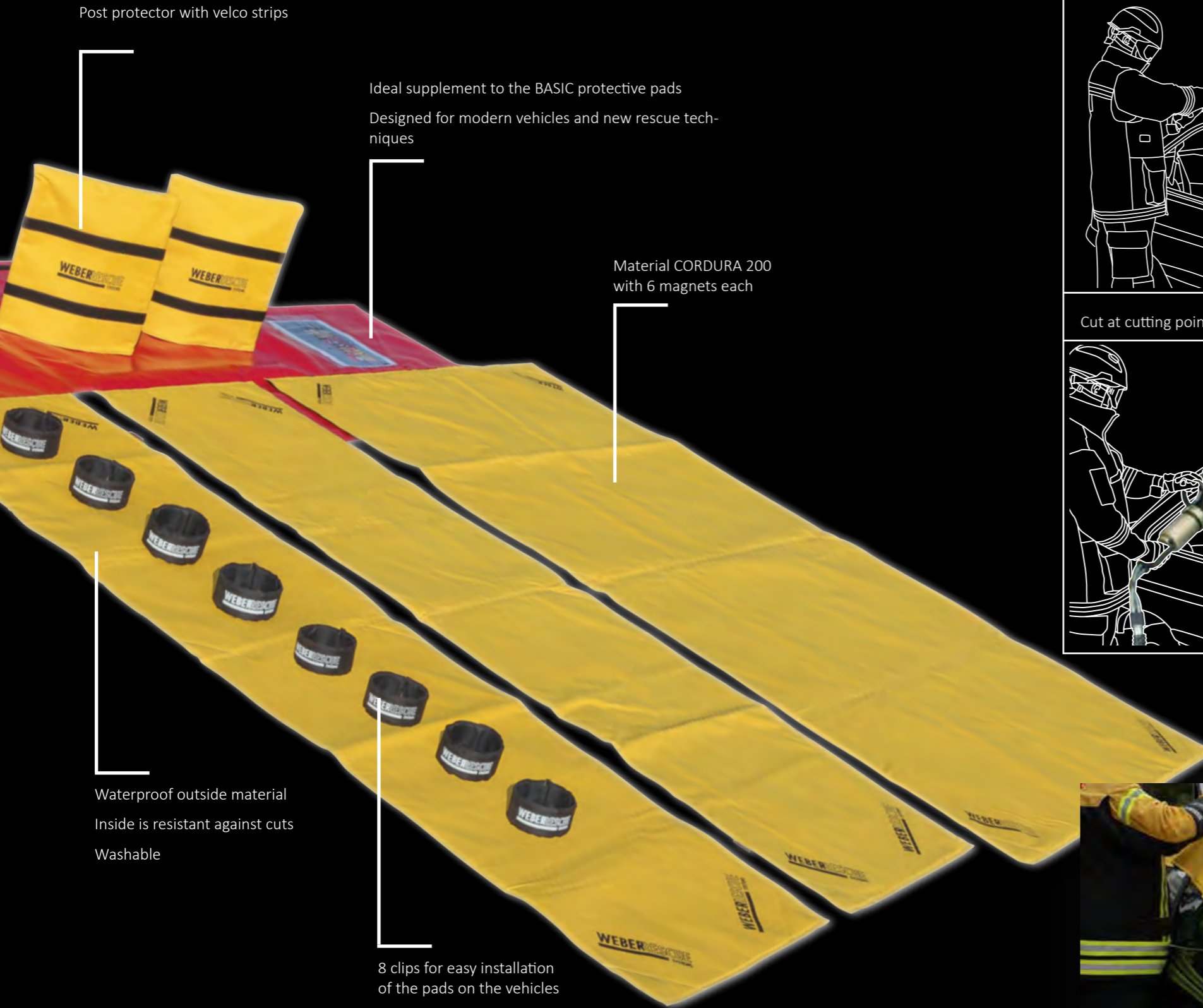

Post protector with velco strips

Ideal supplement to the BASIC protective pads  
Designed for modern vehicles and new rescue techniques

Material CORDURA 200  
with 6 magnets each

Waterproof outside material  
Inside is resistant against cuts  
Washable

8 clips for easy installation  
of the pads on the vehicles

# TIPS AND TRICKS ROOF SECTIONING

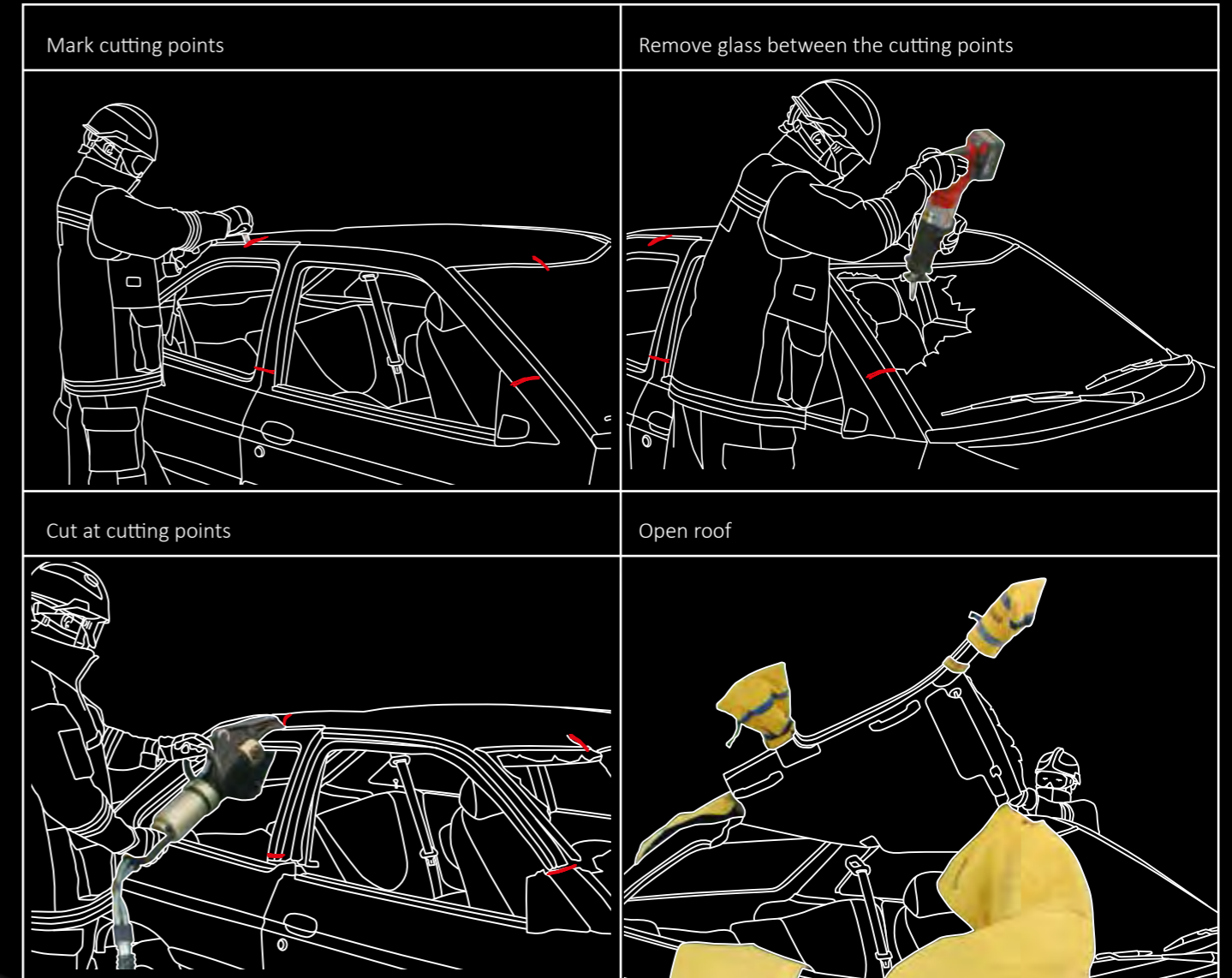

## ACCESSORIES

### GLASS-EX AND CENTRE PUNCH

- To remove laminated windscreens
- Including centre punch to remove safety glass

	Weight	Part no.
Glas-Ex	1.5 kg	8114161
Centre punch	0.06 kg	8027676
Replacement blade		8032858



### PROTECTION SHIELD

- Two different sizes and forms – multifunctional use
- Transparent and flexible

Triangle, flexible – PVC with 2 yellow grabbing hangers Size 600 x 400 x 7 mm	1.2 kg
Rectangle, flexible – PVC with 3 yellow grabbing hangers Size 600 x 400 x 7 mm	2.1 kg
<b>Weight total</b>	<b>3.3 kg</b>
<b>Part no.</b>	<b>8136360</b>

### GLASS MANAGEMENT

- Glass-Ex, centre punch and rescue knife
- Adhesive tape dispenser and protective goggles
- Two pieces rescue foil and prying tool
- In a case with foamed inlay

<b>Dimensions</b>	600 x 400 x 132 mm
<b>Weight</b>	5.6 kg
<b>Part no.</b>	1080917

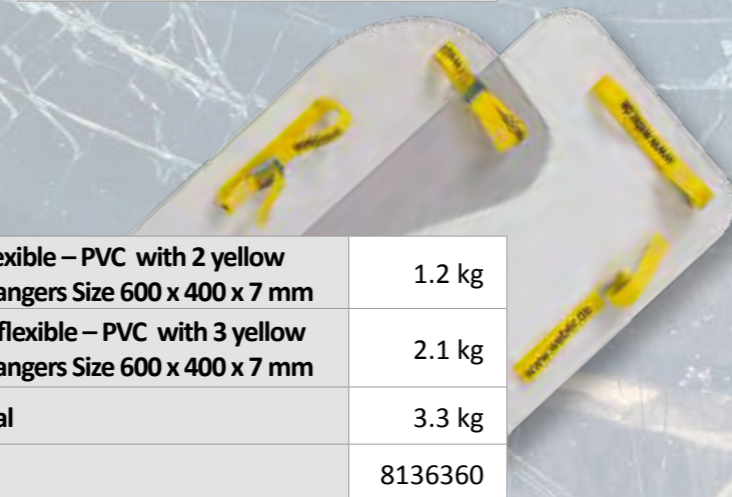

## ACCESSORIES

### ROUGH EDGE PROTECTIVE PADS, ROUGH EDGE PROTECTIVE PADS UPGRADE AND PLUS



Rough edge protective pads with ground sheet		Rough edge protective pads UPGRADE	
Packing Dimensions	700 x 500 x 95 mm	Packing Dimensions	700 x 500 x 160 mm
4 x column protection, with 2 hook-and-loop tape per pad	300 x 350 mm	2 x column protection, with 2 hook-and-loop tape per pad	350 x 400 mm
2 protection blankets, with 4 magnets per blanket	650 x 650 mm	2 protection blankets, with 4 magnets per blanket	400 x 200 mm
1 protection blanket, with 6 magnets	1,650 x 650 mm	1 protection blanket, with 6 magnets	1,100 x 2,000 mm
Weight	7.8 kg	Weight	8.6 kg
Part no.	8135517	Part no.	1078945
<b>8 WEBER-Clips for fixation included!</b>			

<b>Rough edge protective pads PLUS consisting of:</b>		<b>WEBER-Clip individually</b>	
Rough edge protective pads and rough edge protective pads UPGRADE			1078944
Weight	16.4 kg		
Part no.	1078947		



### PATIENT PROTECTION PAD PAT-SAFE

- Flexible, see-through and robust patient protection
- Material CORDURA
- Removable window out of flexible Polyglas 0,3 mm
- With a transport bag

<b>Dimensions</b>	1,600 x 2,000 mm
<b>Weight</b>	1.5 kg
<b>Part no.</b>	1079078
<b>Replacement window</b>	
<b>Dimensions</b>	1,000 x 2,000 mm
<b>Weight</b>	0.6 kg
<b>Part no.</b>	1079079



### PATIENT STABILIZATION SYSTEM PAT-STAB

Multi-useable

- Rescue blanket
- Resporator emergency kit
- Emergency trousers
- Shaft rescue
- For stabilization of patient in side position
- Special applications

<b>Dimensions</b>	2,200 x 750 mm
<b>Weight</b>	11.3 kg
<b>Part no.</b>	1078942

# ACCESSORIES

## HALLIGAN TOOL

- Best accessory for technical rescue
- Available as metal cutter or prying tool
- Different sizes for flexible use
- Various applications
- Handle with nonslip surface

### With prying head

Length	30" - 762 mm	36" - 914 mm	42" - 1,066 mm
Weight	5.5 kg	5.8 kg	5.9 kg
Part no.	8053529	8053537	8053790

### With metal cutting head

Length	30" - 762 mm	36" - 914 mm
Weight	5.0 kg	5.7 kg
Part no.	8052700	8052719

**NEW!**

## FIRE AXE

- Special fire axe to supplement the Halligan tool during forcible entry situations
- Can be used for driving in the Halligan tool into position, as well as a wedge to keep the created gap open
- Due to the extremely flat head the axe can penetrate deeply into the material
- Rounded striking head for optimal power transfer
- Stable and ultra-lightweight fibreglass shaft

## PRACTICAL KIT (SET OF IRONS)

- Combination of fire axe and 30" halligan tool
- Strap to connect the set for carrying

	Fire axe	Set of irons (kit)
Dimension (LxBxH)	930 x 220 x 40 mm	930 x 220 x 160 mm
Weight	3.8 kg	9.6 kg
Part no.	1081980	1081981

# ACCESSORIES

## RESCUE PLATFORM

- Solid aluminium construction
- Adjustable ladders
- Safe adjustment with arresting bolts in 265 mm steps
- Rails equipped with extensions, individually adjustable in 30 mm steps
- Complies to DIN 14830

Packing dimensions	1,050 x 1,790 x 280 mm
Weight	51.0 kg
Part no.	1057597

## TRUCK CAGE SAFETY SYSTEM

- Ratchet with stitched-on lashing strap and eye-clamp
- Lashing strap length 10.0 m
- 2 rim clamps
- 2 x round sling length 3.0 m with 2.0 m hose
- Including suitcase

Dimensions	600 x 400 x 132 mm
Weight	8.0 kg
Part no.	1083472

## AIRBAG PROTECTION OCTOPUS

- Suitable for all types of cars and trucks
- Lightweight

Airbag protection cars driver side	
Dimensions (LxWxH)	400 x 300 x 132 mm
Weight	1.7 kg
Part no.	1083470
Airbag protection cars passenger side in bag	
Dimensions (LxWxH)	400 x 300 x 132 mm
Weight	3.8 kg
Part no.	1083471
Airbag protection trucks driver side in bag	
Weight	0.8 kg
Part no.	8046204

**NEW!**



## ACCESSORIES

**NEW!**

### CHAIN RESCUE KIT

- Complete chain rescue kit with all necessary materials to ensure a safe and fast chain rescue
- The high-performance chains (quality class 12) are particularly light in weight and have square chain links, which ensure an extreme grip, when wrapping car columns.
- The 3 m long chains can be adjusted in length by a shortening hook (with securing bolts)
- Designed for use on a 50 kN winch!
- Including weight blanket for better visibility of the steel cable and for protection against straining
- Packed in 2 transport cases (front and rear of the car)

Dimensions	600 x 400 x 132 mm
Weight case 1	22.0 kg
Weight case 2	23.5 kg
Total weight	45.5 kg
Part no.	1084562

### WEIGHT BLANKET FOR STEEL CABLE

- For better visibility of tensioned winch cables, especially at night and in poor weather and visibility conditions
- Just put the weight blanket over the steel cable and fix it with integrated magnets
- Due to the weight of the blanket, possible whipping and striking from a tearing steel cable is significantly reduced (cable falls to the ground)
- Therefore the immediate danger area is reduced (blanket in the middle of the cable)
- Made of tear-resistant Cordura, including 2 reflector stripes and an abrasion protector
- Informs to keep a safe distance in German and English

Dimensions	550 x 700 mm
Material	Cordura (Nylon fabric)
Weight	1.5 kg
Part no.	1084561

**NEW!**

## ACCESSORIES

### BATTERY-LIGHTING LED QUICKLIGHT 28V

- For precise illumination of the incident site using 4 LED spotlights
- Each spotlight can be tilted and inclined individually
- 50 watts per LED spotlight, 6.000 lumens (total)
- 2 or 4 spotlights switchable
- Power supply via replaceable battery (28 V Milwaukee)
- Approx. 35-40 minutes lighting duration with 4 LEDs and a 5,0 Ah battery (continuous operation is possible via optional power supply)
- Foldable and rubberized feet ensure a stable platform
- Includes a mounting point for standard tripods and a carrying-frame



Dimensions (Transport)	430 x 120 x 370 mm
Dimensions (Operation)	480 x 280 x 370 mm
Weight (without battery)	8,0 kg
Protection class	IP54
Power consumption	4 x 50 W
Luminous color	4500 Kelvin
Part no.	1084044

### BASE SUPPORT AND SILL SUPPORT

- Ideal addition to rescue rams
- For supporting rescue ram in centre channel and on door sills
- Prevents slipping of the rescue ram
- Sill support updated, especially suitable for modern vehicles!

	Weight	Part no.
Base support front	6.0 kg	1824333
Base support back	9.8 kg	1824341
Sill support	12.3 kg	1085337

**NEW!**

Sill support



Base support back



Base support front



## ACCESSORIES

### RIM ADAPTERS

- Ideal addition to rescue rams to be used on lorries and buses
- With carrying case



	Weight	Part no.
Rim adapters back wheel	19.6 kg	2852144
Rim adapter set back and front wheel	30.7 kg	2854082

### POWER WEDGE SPK 250

- Insertion height only 8 mm
- Creates initial opening for a pneumatic lifting bag
- Up to 61 mm lifting height
- Lifting force 25 to
- EN 13204 and NFPA 1936 tested
- Also available in E-FORCE 2-Version (page 39)



	SPK 250	SPK 250 E-FORCE 2
Weight	9.3 kg	12.6 kg (incl. battery)
Part no.	1822861	1077812

### HAND PUMP DPH 4018-SA

- Two-stage, can be used even when not in a horizontal position (up to a maximum inclination of 20°)
- Oil volume 2.5 l
- Complete with pair of hoses 5 m, with couplings, mounted on a wooden board
- Complies to DIN 14751

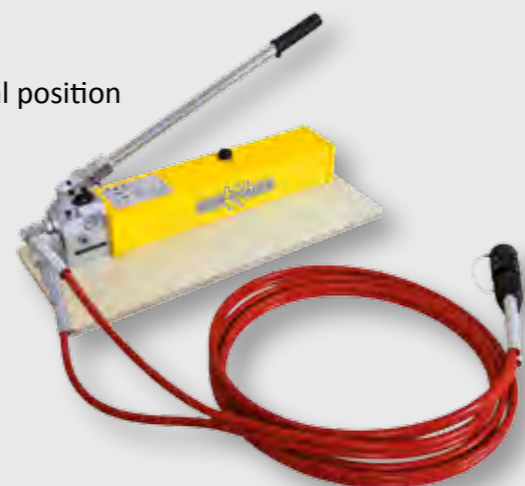

Weight	14.6 kg
Part no.	1051174

## ACCESSORIES

### CRASH RECOVERY SYSTEM®

#### Comprehensive and up to date

- Database containing all mass-production series vehicles with airbags or alternative propulsion for cars, vans, light and heavy trucks as well as buses

#### Full information

- Consistent, easy to read vehicle graphics
- Information on all rescue relevant vehicle components
- Extensive background information, photos and disabling instructions

#### Saves time, increases safety

- No searching for components, know what's inside!
- Disabling instructions allow for a quick mitigation of hazards

#### Mobile, flexible, easy to use

- Available Microsoft Windows, Apple iOS (iPAD) and Android
- CRS license independent of operating system, OS can be changed later

#### Crash Recovery System® contains information about:

- Airbags and Airbag inflators, Seatbelt pretensioners and automatic roll bars
- Reinforcements, Batteries and fuel tanks
- Alternative propulsion components, such as high voltage batteries, gas tanks, disabling procedures
- Truck and bus components, such as chassis suspension, emergency exits, sleep cabins, lifting points

ID-No.	Content and Licence
1052784	Lite Edition for Windows, Apple iOS or Android (1 year license) <ul style="list-style-type: none"> <li>• Databases for Europe, USA, UK and Pacific region</li> <li>• Graphics with all locations of safety components and danger zones</li> <li>• Manual vehicle selection</li> <li>• Monthly online updates for software and database maintenance</li> </ul>
8049335	Standard Full Edition for Windows, Apple iOS or Android (1 year license) <ul style="list-style-type: none"> <li>• Databases for Europe, USA, UK and Pacific region</li> <li>• Interactive graphics with single click access to all component information</li> <li>• Digital photos</li> <li>• Deactivation procedures for vehicles with alternative propulsion</li> <li>• Manual vehicle selection using make, model, bodystyle and model year</li> <li>• Monthly online updates for software and database maintenance</li> </ul>
8060169	1 year database subscription renewal

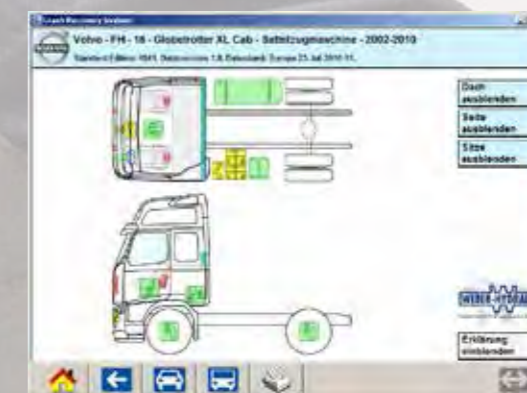
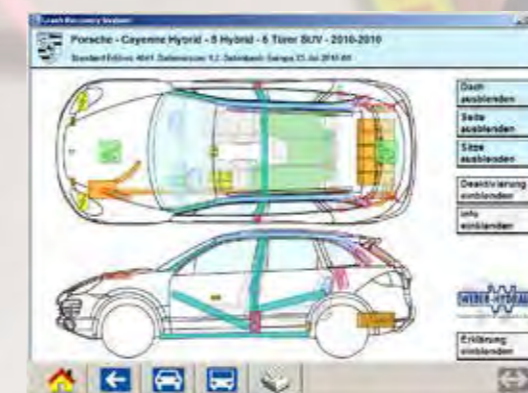

## WEBER RESCUE FANSHOP

Useful additional equipment like

- Fashion
- Gadgets
- Tools
- PSA
- Education
- Merchandising

Vouchers from 10 to 100 EURO also available.

You can find all products also in our separate fanshop catalogue.

Or you order online [www.weber-rescue-shop.com](http://www.weber-rescue-shop.com) and become a fan on facebook [www.facebook.com/weberrescueshop](http://www.facebook.com/weberrescueshop).



## TRAINING

### RESCUE DAYS

- The worlds largest training event on technical rescue
- Takes place once a year in Germany (each year different locations)
- Appr. 600 participants form more than 20 different countries
- 80 international trainers (fire fighters and rescue services)
- Theory and practice
- Location 2018 Bostalee (Saarland)

Training Programme	Part no.
<b>RESCUE DAYS (2 days)</b>	8051550
<b>Module 1 - Large vehicles (1 day)</b>	8055084
<b>Module 2 - Rescue techniques (1 day)</b>	3250060
<b>Module 3 - RESCUE DAY Compact (1 day)</b>	8055092

# rescuedAYS





1058684

**WEBER-HYDRAULIK GMBH**

Heilbronner Straße 30  
74363 Güglingen/Germany  
Telefon +49 (0) 7135/71-10270  
Telefax +49 (0) 7135/71-10396  
info@weber-rescue.com

Industriegebiet 3 + 4  
4460 Losenstein/Austria  
Telefon +43 (0) 7255/6237-120  
Telefax +43 (0) 7255/6237-12461  
info@weber-rescue.com

**WEBER**RESCUE  
SYSTEMS

[www.weber-rescue.com](http://www.weber-rescue.com)